

Simple and Cheap Transverter for 10 GHz

Paul Wade, W1GHZ ©2016

w1ghz@arrl.net

see 2024 Appendix

I have been working on cheap and simple microwave transverters for the past 10 years, covering all bands through 5.7 GHz. Although 10 GHz is one of the most popular microwave bands, there are still technical challenges to overcome. It has taken several attempts and some lessons learned to develop a 10 GHz transverter that I believe to be reproducible and affordable – the cost should be under \$100.

There are at least two good commercial transverters available, but the expense may be a barrier to those who aren't sure they are ready for 10 GHz. The other alternative, surplus, is less available than it was when many of us got started.

Design

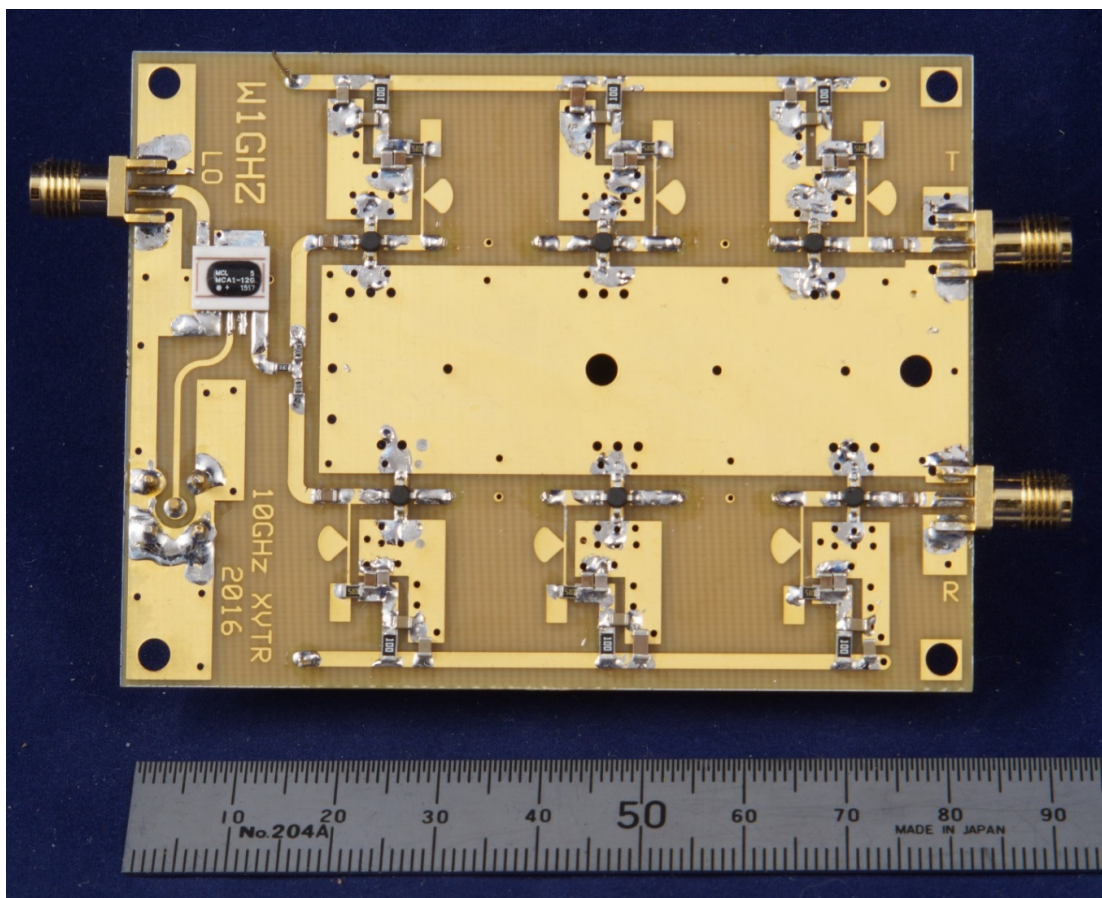

Figure 1 – Circuit side of 10 GHz Transverter

The 10 GHz transverter, shown in Figure 1, looks a lot like the 5760 MHz transverter¹ – three MMIC stages for transmit and three for receive, with pipe-cap filters between stages. The differences are that everything is smaller. The pipe-caps are ½ inch rather than ¾ inch and the quarter-wave bias stubs are shorter. Most important, the PC board is thinner, 1/32 inch rather than 1/16 inch. One thing I learned while developing this transverter is that ordinary 1/16 inch PC boards radiate badly at frequencies above about 7 GHz – more about this later.

The design philosophy is the same as the lower frequency Cheap and Simple Transverters²: **Gain is Cheap**, provided by inexpensive MMICs. We use the cheap gain to overcome losses of the other components – ordinary chip capacitors and resistors, rather than expensive microwave parts. The PC board is ordinary FR-4 material rather than expensive Teflon boards. Ordinary copper plumbing pipe-caps provide the filters³. The only microwave component is the mixer, and Minicircuits⁴ offers surface-mount mixers at reasonable prices.

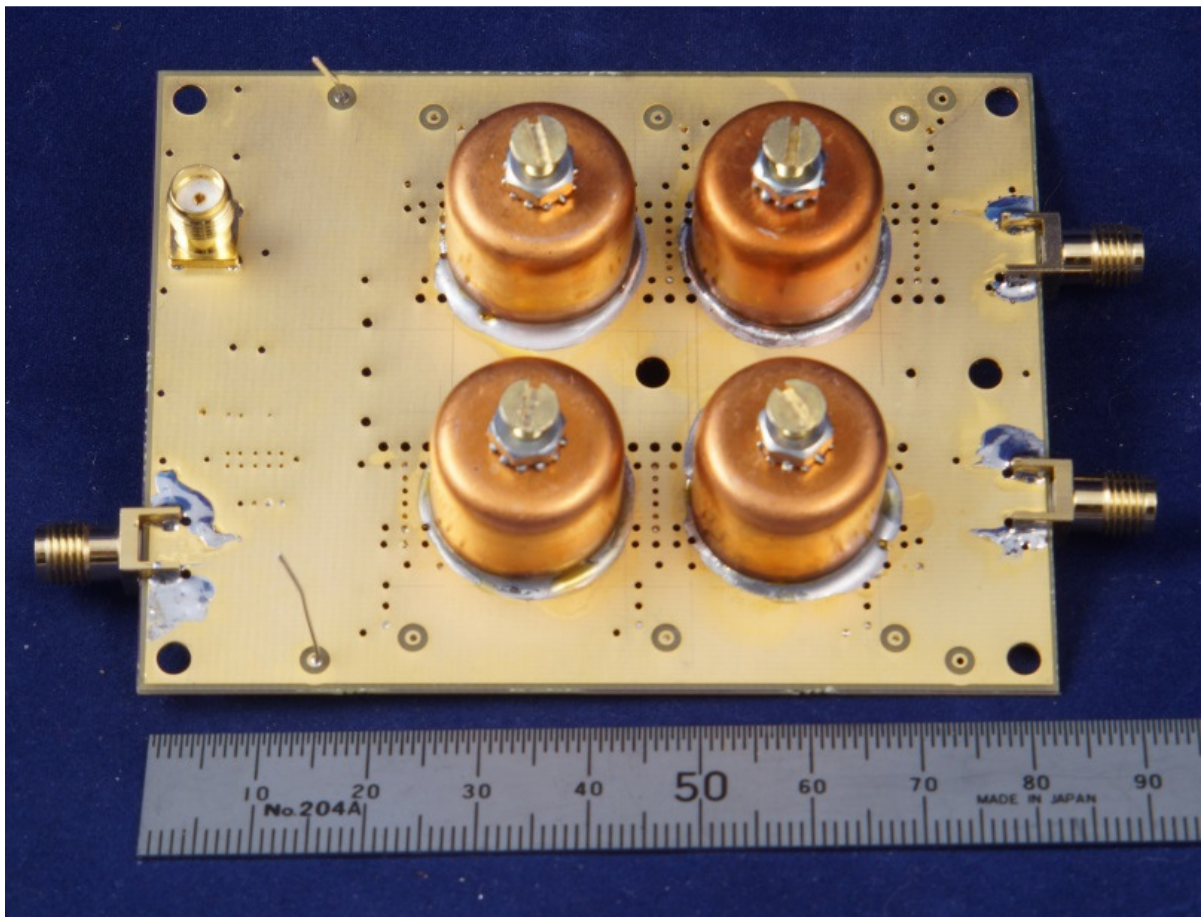

Figure 2 – Pipe-cap filter side of 10 GHz Transverter

I have only found one MMIC that works well at 10 GHz, the RFMD NLB-310. Consequently, all six amplifier stages are identical and use this device, as shown in the schematic, Figure 3. There will probably be other good MMICs in the future, so the PC board has footprints which will accommodate both the older 4-lead package and the newer SOT-89 package. In addition to the MMICs, there are only three resistor values and four capacitor values used.

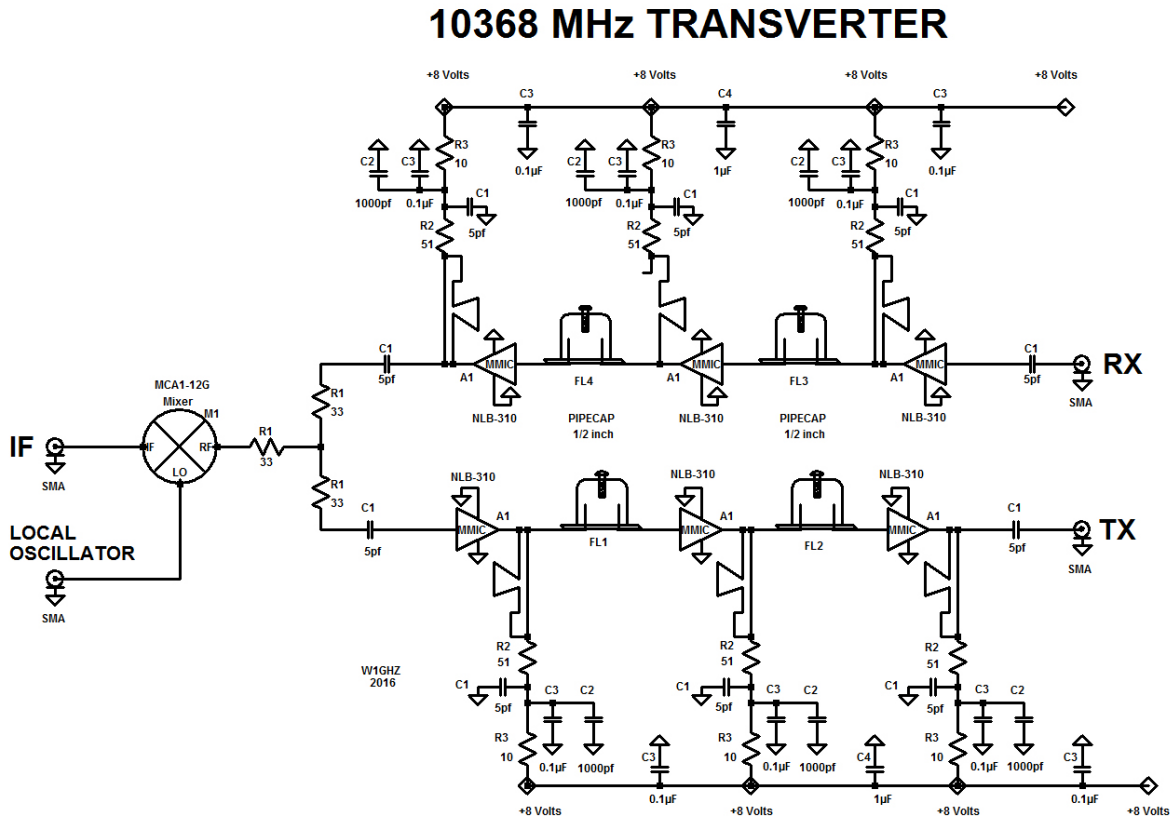

Figure 3 – 10 GHz Transverter Schematic Diagram

Updated in 2024 Appendix

Performance

This is a basic transverter, with power output of 5 to 10 milliwatts and Noise Figure around 8 or 9 dB, enough for any line-of-sight path. For higher performance, you may add power amplifiers and low-noise amplifiers – a satellite TV LNB can be modified for a good preamp. Local oscillator power >+5 dBm is needed for best performance, but the transverter still works at lower levels. I tested it down to about +1dBm of LO injection, and output was down a few dB. LO feedthrough is down perhaps 25-30 dB, but I don't have a spectrum analyzer to get accurate numbers.

The pipe-cap filters, with two pipe-caps separated by amplifiers in each direction, provide a bandwidth of about 70 MHz with 4mm probes.

Circuit details

The PC board is ordinary FR-4 dielectric, probably quite lossy, but **Gain is Cheap**. The board is 1/32 inch thick, which seems thin enough to keep radiation tolerable – anything more than an inch away has minimal effect. With thicker 1/16" board, radiation was noticeable at 5 inches.

A closeup of one of the amplifier stages is shown in Figure 4, with the components identified. All six amplifier stages are identical and use the same component identification.

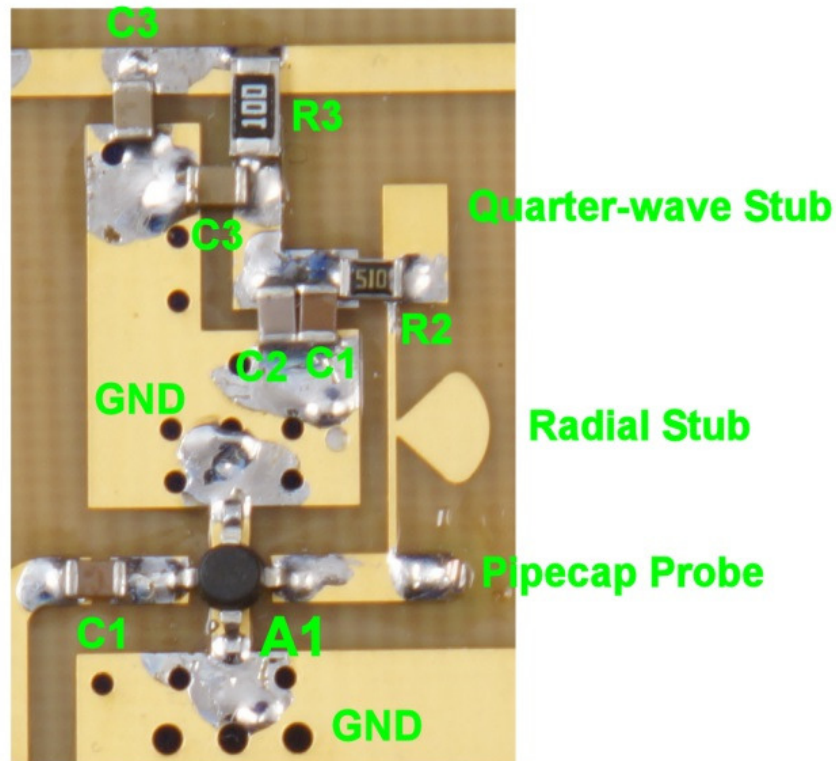

Figure 4 – All amplifier stages are identical

The NLB-310 MMIC (Digikey⁵ 689-1004-1-ND) is straightforward, 50 ohms in and out, but the bias network might need some explanation. The quarter-wave stub at the top is open-circuit at the top end, so the bottom end is transformed by the quarter-wave to be a virtual ground. Then the narrow line is a high-impedance transmission line, also $\frac{1}{4} \lambda$ long, which transforms the virtual ground back to an open circuit. If this much works, then all the other resistors and capacitors have no effect at 10 GHz – they are there for decoupling at lower frequencies. Low frequency decoupling is important because MMICs have higher gain at lower frequencies and will readily oscillate without the decoupling capacitors to short out low-frequency paths.

The radial stub has the same properties as a quarter-wave stub, but over a wider bandwidth, so the size isn't as critical. It produces a virtual ground at the connection point to the narrow line. The narrow line is another high-impedance $\frac{1}{4} \lambda$ transmission line, transforming the virtual

ground back to an open circuit at the 50 ohm RF line from the MMIC. Thus the bias network delivers voltage to the MMIC with almost no effect at 10 GHz – you can poke around with your finger to prove it.

The only components that should be at all critical are the series blocking capacitors, C1, and the SMA connectors. I used ordinary 5 pf ceramic chip capacitors (AVX 08051A5R0XAT2A, Digikey 478-6039-1-ND). If you are so inclined, you could try real ATC microwave capacitors and see if there is any difference.

The rest of the transverter is the mixer and power splitter, shown in Figure 5. The mixer is a Minicircuits MCA1-12G, which can be purchased in single quantities. The Minicircuits.com website will recommend a similar, slightly cheaper model, but the MCA1-12G has small leads extending from the package which makes it easier to verify proper soldering.

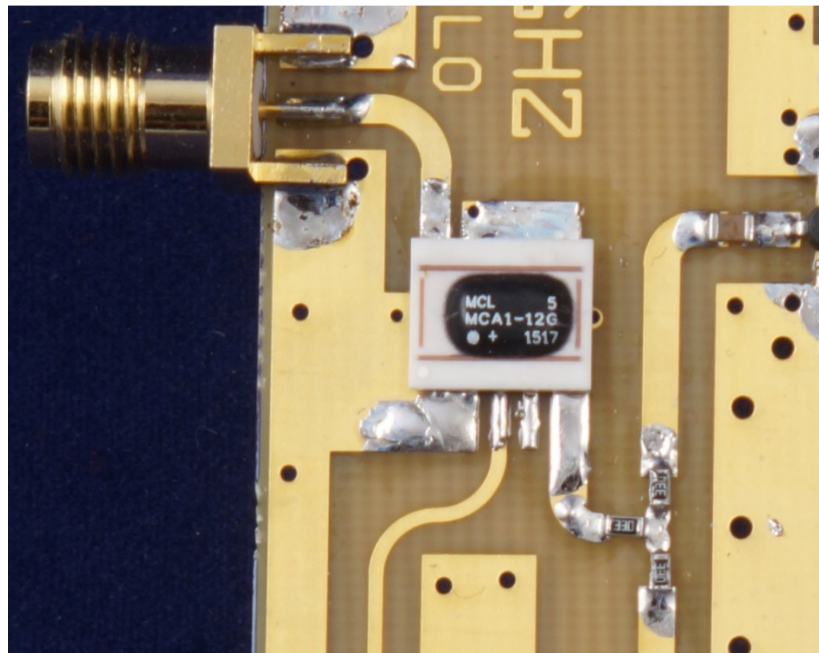

Figure 5 – Detail of mixer and power splitter

The power splitter is comprised of the three 33-ohm resistors below and to the right of the mixer. I used smaller 0603 size chip resistors, but larger 0805 size would probably work as well. To the upper right of the mixer is the blocking capacitor and MMIC for the transmit side, connected to the power splitter.

The SMA connector in Figure 5 is the LO port. For all the lower bands I successfully use cheap Chinese SMA connectors from ebay, but I decided to stick to name brand for 10 GHz. These are by Taoglas (Digikey 931-1175-ND) for around \$3 each, but more expensive Amphenol connectors would be fine.

Construction

The first step in assembly is to solder the pipe caps to the board, after drilling and tapping the 4-40 screw holes in the top of the caps. Each pipe-cap location on the PC board has a hole at the center, halfway between the probe locations. I scribe lines on the bare board half the pipe cap diameter away from the center hole, making a square to line up each pipe cap. Then I put a bit of paste flux on the rim of each cap, place the caps in position, and put a ring of wire solder around the base of each cap. I solder the caps one at a time, holding the one being soldered in position with a screwdriver while heating the top of the cap with a hot air gun. The copper conducts the heat down to the board; when the joint reaches temperature, the ring of solder melts and flows around the base of the cap, without overheating the board. As soon as the solder flows, remove the heat, let it cool until the solder solidifies, then move on to the next cap. A torch could also be used, but tends to oxidize the copper, and might damage the thin PC board.

A note on pipe caps. I have found three different brands at local stores and any of them should work fine. What they all have in common is that the open end is not very uniform, so sanding on a flat surface with 220 grit Wet-or-dry sandpaper is needed to make them sit level and solder cleanly. About 20% of them are so bad that too much sanding is required, so I toss them.

Figure 6 – Installing probes in Pipe-cap Filter

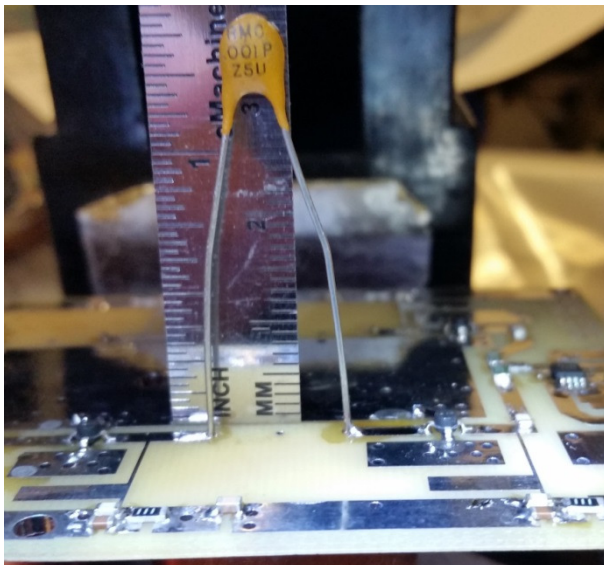

Brass screws are preferred for pipe-cap tuning, with a lockwasher. The probes are just bits of wire – I keep them straight and the desired length by using leads from an ordinary disc capacitor, as shown in Figure 6. Measure the full lead length, then insert it until the desired length is inside, and allow another 0.8 mm for the board thickness. The probe length inside the pipe cap is about 4.5 mm. Since it is hard to get the length exact, slightly longer is probably better than too short, which would be lossy.

Even better than the disc capacitors are larger capacitors with the right lead spacing, like the ones in Figure 7. I found a bunch of these being used for soldering practice. The probe length can be eyeballed with a scale as shown in Figure 6, or you could make a gauge block to make them more uniform.

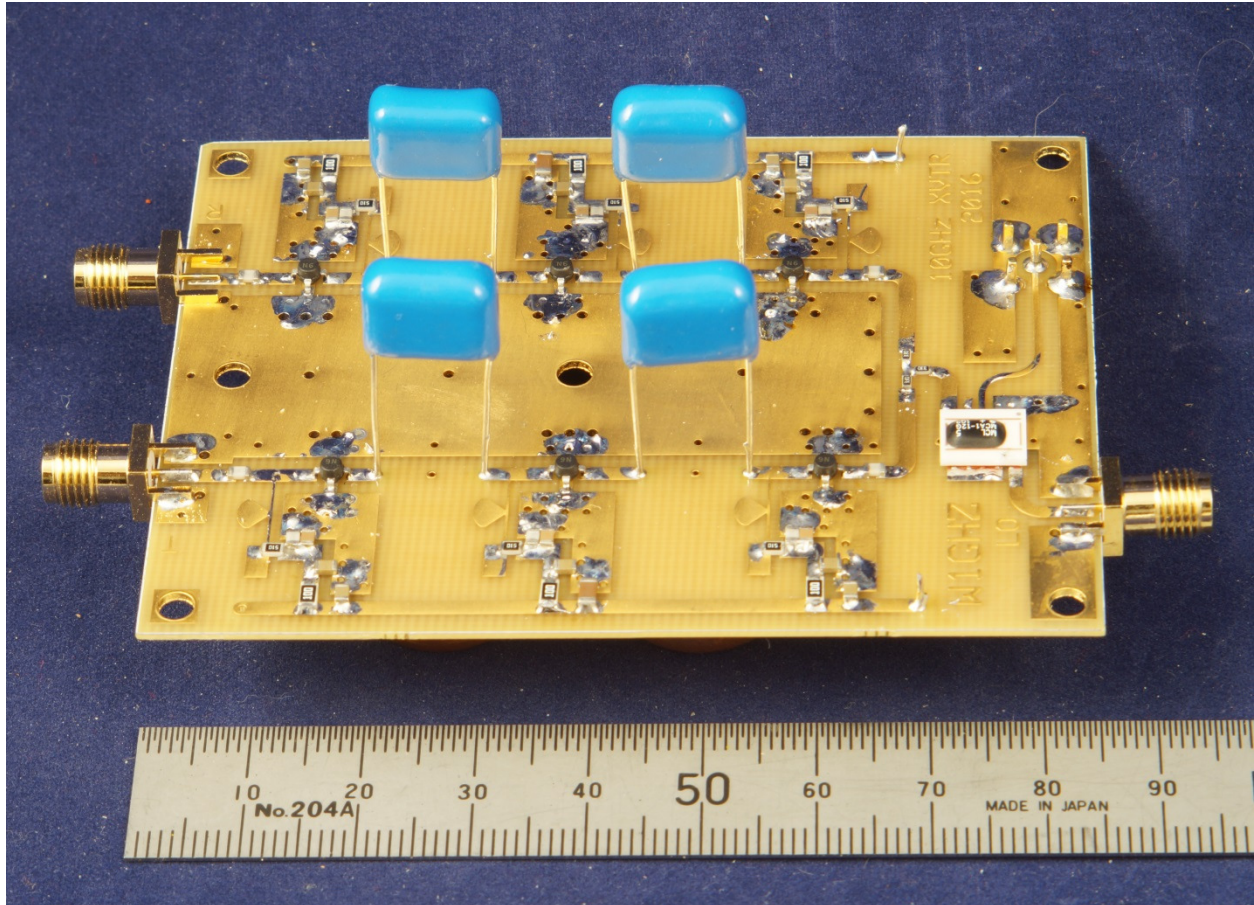

Figure 7 – Capacitors with perfect lead spacing make probe assembly easier

All the other parts are surface mount and are easily soldered with a fine-tip iron and thin solder. The RF chip capacitors and resistors are the medium 0805 size, while the DC resistors and 0.1 μF bypasses can be the larger 1206 size.

Referring back to Figure 4, I usually start with R2 and work around the bias components in order. The plan is that the second solder joint on each component leaves a nice solder pad for the next component – sometimes it works. Then I add the MMICs, the power splitter, and the mixer, and finish up with the SMA connectors. In some areas, the pipe-caps act as a heat sink and a larger soldering iron is needed to properly flow the ground connections.

Tuneup

The only things to tune are the pipe-cap filters. I use 4-40 brass screws, ½ inch long; the length protruding from the pipecap after tuning is about 0.28 inches, or about 7 mm. So a good starting point is with the screws not quite as far into the pipecap. With a power meter or detector on the TX output, apply 8 volts to the transmit side and put the LO power (ideally about +7 dBm) into the LO port. There is enough leakage thru the mixer to see some TX output when the transmit pipecaps are tuned to the LO frequency, so alternately turn the tuning screws clockwise until you see some output. Then back the screws out until the output is nearly gone. Now add some IF input power, around 0 dBm at 144 MHz. The output power should increase – back the screws out further to peak the output. Vary the IF power level to be sure the output power also varies.

Tuning up the receive side is even easier. First, measure the protrusion of the transmit tuning screws and set the receive screws to the same depth. Connect the IF output to a receiver and apply a weak signal to the RX input. Peak the signal on the receiver. If you have a Noise Figure meter, you could make a final adjustment.

History

I have learned some lessons as I developed this transverter and the lower frequency versions. Education is always expensive. Learning from experience is valuable, and it doesn't always have to be personal experience. Sharing some of my lessons might help you avoid making the same mistakes so that you can move on to other lessons.

My first transverter was the prototype for the first Down East Microwave 10 GHz transverter, some 20 years ago. Steve has certainly improved it and made the performance much better. You might have decided by now that the additional performance is worth the additional expense, but you would miss the satisfaction of building your own equipment.

The 10 GHz transverter used thin Teflon PC board and pipe-cap filters. The thin Teflon is not only relatively expensive, but is also flimsy and requires a supporting structure and a way to attach SMA connectors. The mixers were printed on the board as well as the LO multipliers. MMICs were the ERA series, new at the time and the only ones then available with any gain at 10 GHz.

I can't take a good picture of the prototype because it is still in a lender rig, making contacts nearly 20 years later. I worked it last summer. So here is a scan of a picture from the original paper⁶:

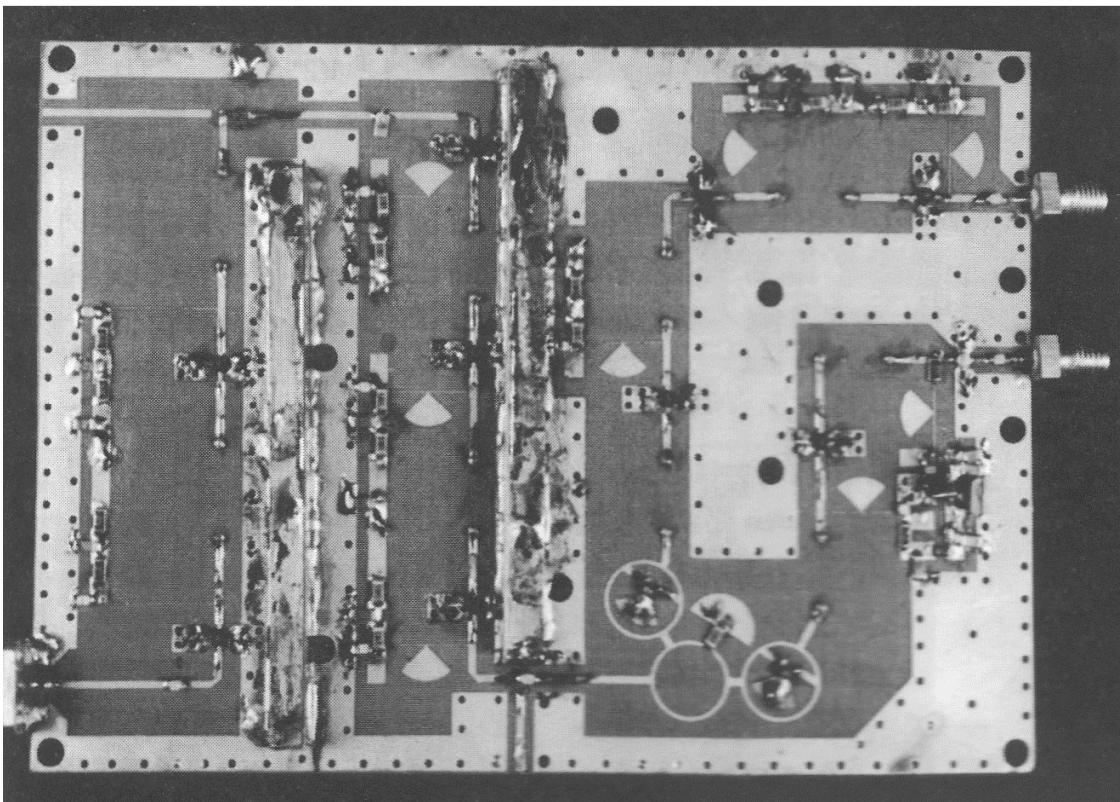

Figure 8 – Original 10 GHz Single-board Transverter Prototype

Since then, some of the things I learned while developing the cheap and simple transverters:

- Gain is cheap – MMICs have become inexpensive and readily available
- Ordinary PC board is good enough if gain is cheap to overcome losses
- Packaged mixers can be cheaper than board area for printed mixer
- Separate LO makes tuneup easier, allows more options
- Ordinary chip capacitors are good enough (two in parallel can be better than microwave capacitors)
- Ordinary 1/16" thick PC board radiates badly above about 7 GHz
- Cheap ebay SMA connectors from China work well up to at least 6 GHz
- Parts are cheap, but many different values adds to cost

My first 10 GHz attempt at a cheap and simple transverter was simply a shrink of the 5760 transverter on 1/16 inch PCB, shown in Figure 9. It used a Hittite mixer, like the first version of the 5760 transverter. Performance was poor, with very low output power. My (wrong) diagnosis was that another stage was needed for more gain.

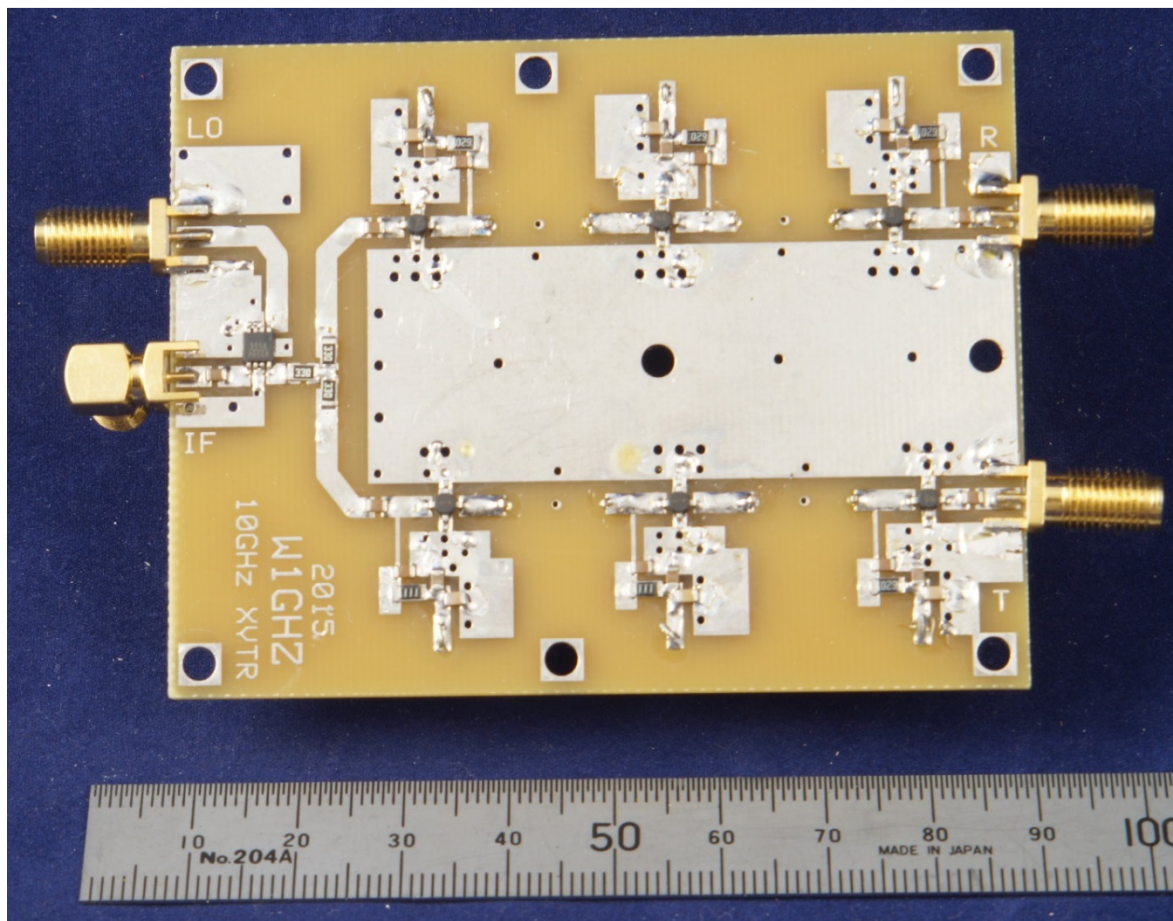

Figure 9 – First attempt at a cheap and simple 10 GHz Transverter

The next version, in Figure 10, simply added an additional amplifier stage at the antenna for both RX and TX. The picture was taken before I added the additional MMICs – apparently I ran out. This one had plenty of gain, but it changed every time I moved, so tuning was really hard. Anything closer than about 5 inches made a large change – the PCB was radiating badly. So a thinner PC board is needed.

I was able to see that the transmit side worked, but the receive side did not work at all. NADA! After much hair-tearing, it appeared to be the Hittite mixer, so I hacked up a board to measure the mixer alone. The mixer worked as specified as an upconverter, but not as a downconverter. I don't know why, but decided to switch to a Minicircuits mixer.

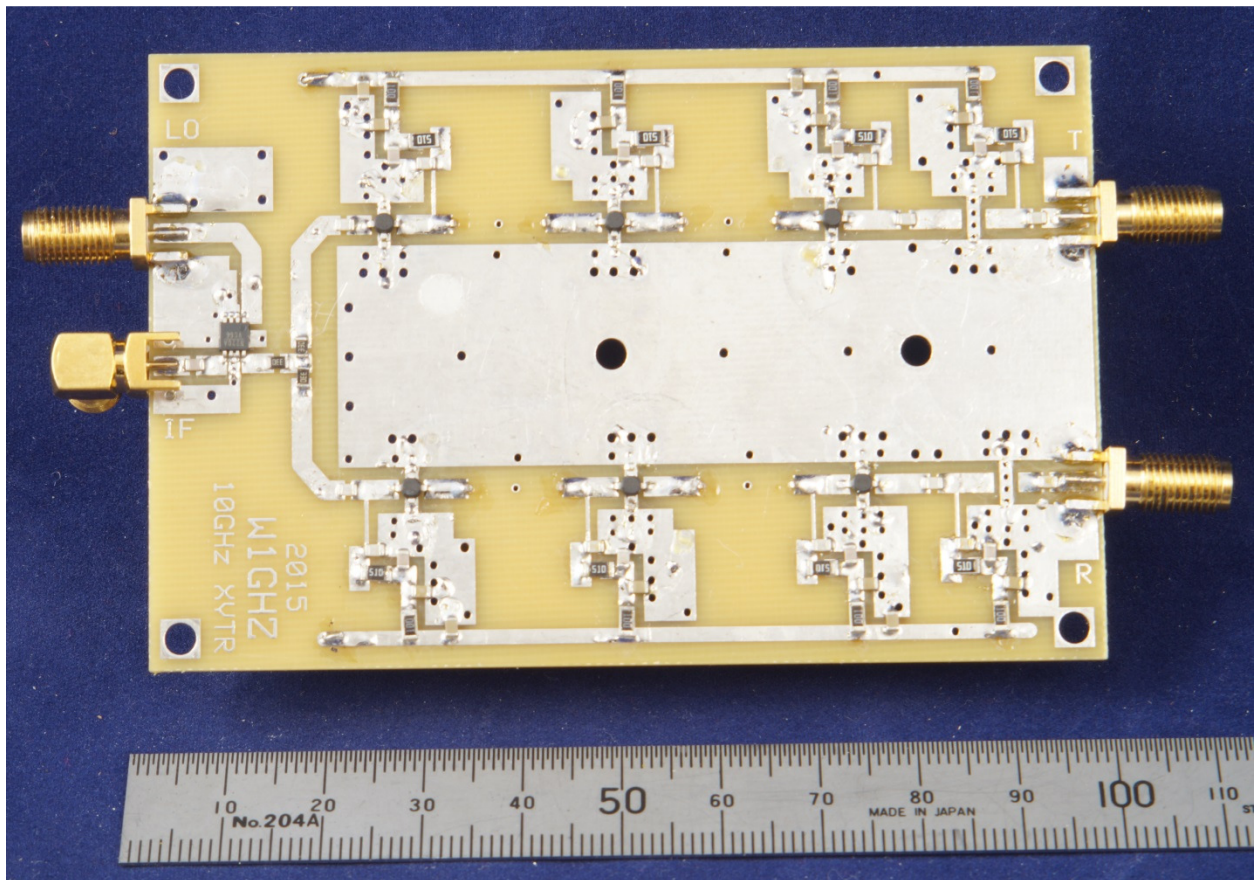

Figure 10 – Four-stage version of Figure 9

I had always gone to ExpressPCB for cost-effective PC boards, but they don't offer thinner ones. However, they do offer four layer boards, with two inner planes and two surface layers for circuitry. The dielectric thickness above the planes is 12 mils, which seemed good, and the thick layer between the planes adds rigidity. I modified the line widths for the thinner dielectric for the version shown in Figure 11. The mixer is now a Minicircuits MCA1-12G.

This version was difficult to tune, so I swept the transmit side with a network analyzer. The response had several large suckouts, especially one at about 10.35 GHz which would not tune. This made the board unusable at 10.368 GHz. I hacked up a board to try just a single amplifier stage to try and isolate the problem, but it still had the large suckout. One problem with the ExpressPCB software is that the two inner planes cannot be connected directly together by a plated-thru hole – this may relate to the suckout.

I also hacked out a section to test the mixer alone. The Minicircuits mixer worked perfectly even with LO power much less than the specified +7 dBm.

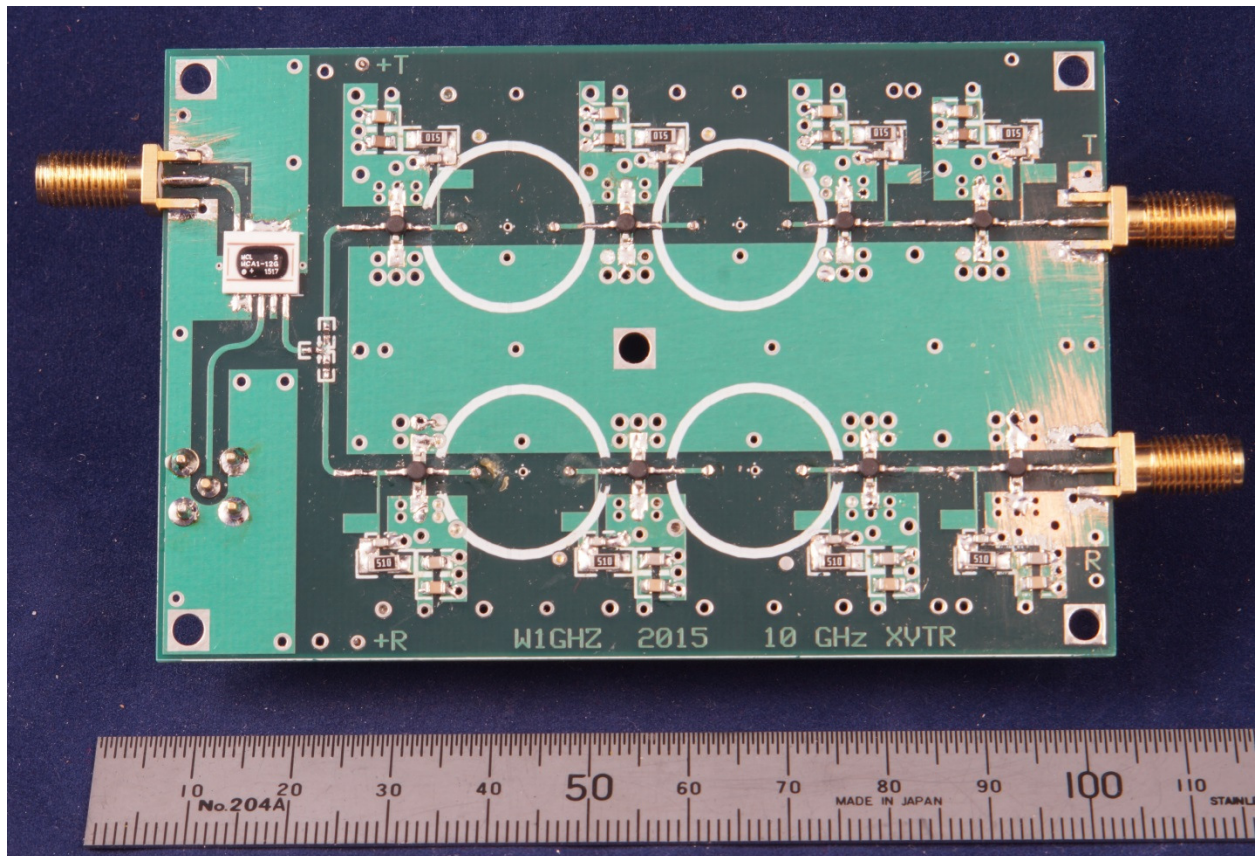

Figure 11 - Cheap and simple 10 GHz Transverter attempt on 4-layer PC board

It was time to try a different supplier for a thinner board. I modified the line widths for 0.020 inch thick PCB, then used the Copper Connection software from Robot Room to convert the proprietary ExpressPCB board file to a standard Gerber file.

This version, on 0.020 inch thick PCB is shown in Figure 12. The bias networks have been changed to include radial stubs, to improve decoupling. There are still four amplifier stages in each direction, which proved to provide too much gain, with some signal bypassing the filters. Hacking off the output stage of the transmit chain and fitting an SMA connector showed that three stages is adequate.

The problem with this version is that I was unable to find edge-mount SMA connectors for 0.020 inch thick board, only for 0.032 inch thickness. These connectors did not sit solidly so performance the output was never steady, making tuning really difficult.

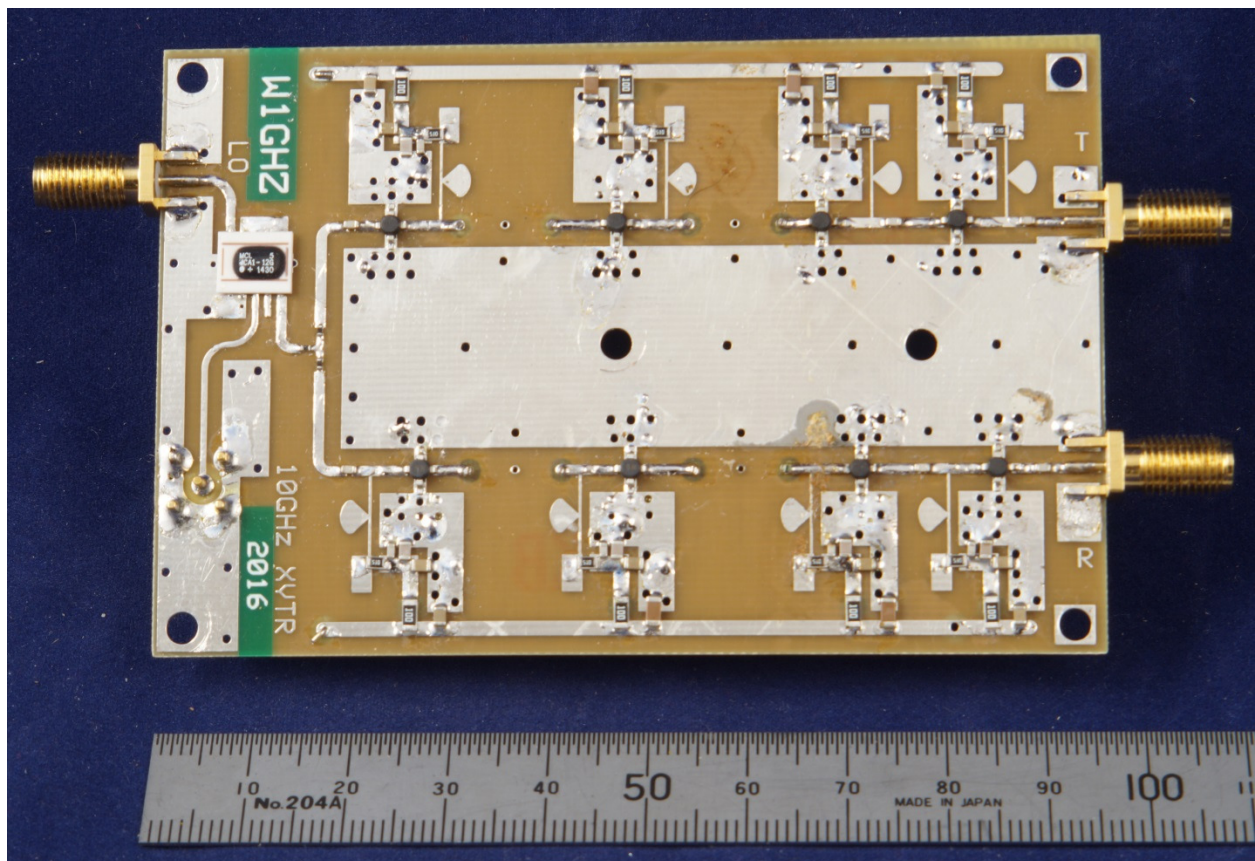

Figure 12 - Cheap and simple 10 GHz Transverter version on 0.020" thick PC board

The obvious next step was 0.032 inch thick PC board; the question was whether it would be thin enough not to radiate badly. I modified the line width again, eliminated the fourth amplifier stages, and found a supplier who included thicker copper on the thin board, which might provide lower loss. This final version, in Figure 12, also included gold-plating on the copper – it is probably not thick enough to make much difference for RF, but it does solder nicely. This one works pretty well – I built two copies, with similar performance. Objects more than about one inch away have little effect, suggesting that radiation isn't too bad.

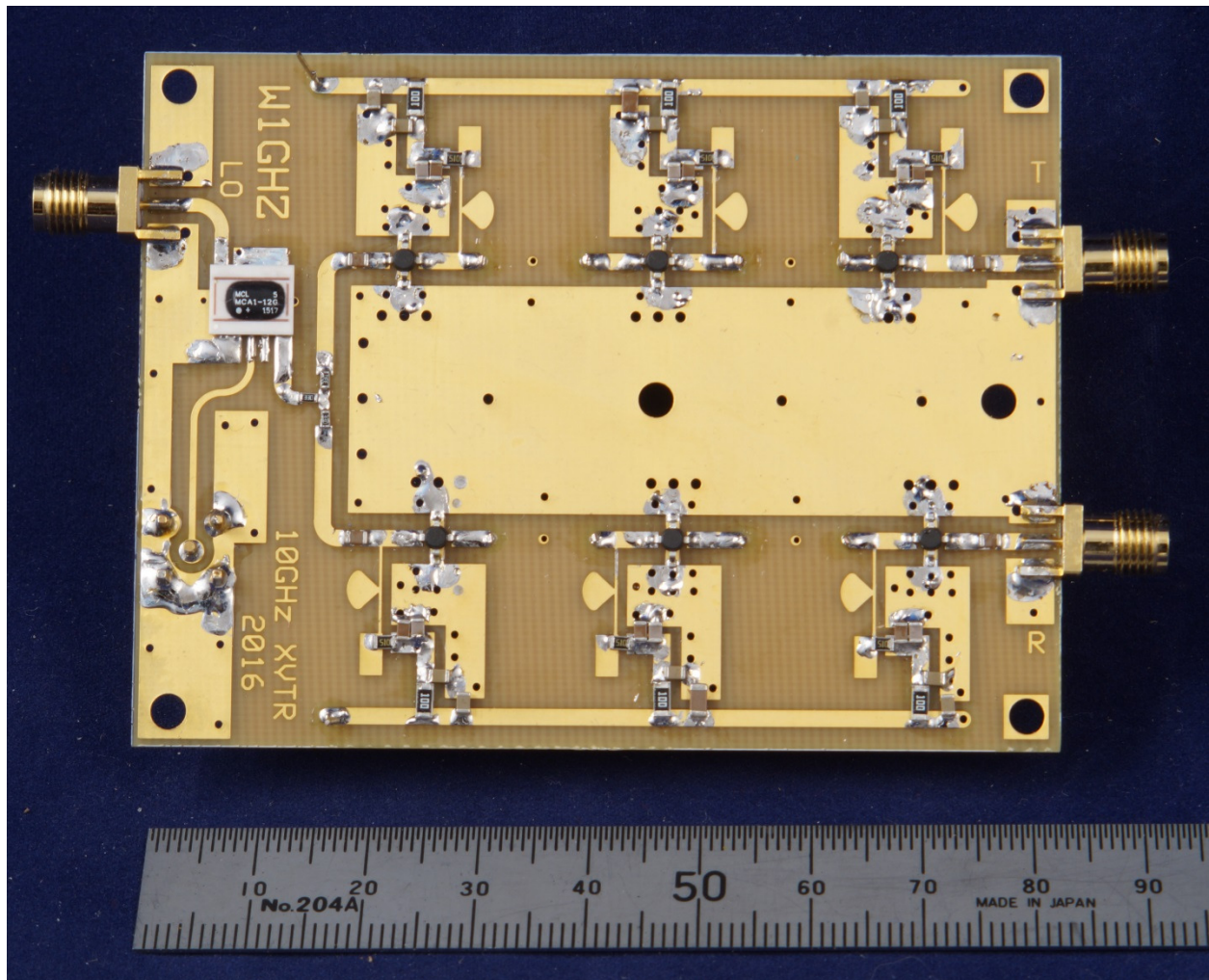

Figure14 – Final Cheap and simple 10 GHz Transverter on 0.032” thick PC board

All these PC board experiments were rather expensive, but the total is still probably less than the setup and lot charge for a Teflon PC board – making plated-thru holes in Teflon board is difficult so the cost is high. I also built a lot of transverters, enough so that I can put one together in less than two hours after the pipe-caps are soldered on. And I learned a lot; perhaps some of these lessons might help you as well.

Local Oscillator

The local oscillator is separate from the board, which enables lots of options. Since the LO and IF ports are untuned, the IF frequency is set by the LO frequency – a 432 MHz IF works just as well as 144 MHz. One possibility is one of the old brick oscillators, which work well but require a lot of power. Multiplier chains from a crystal oscillator or from a synthesizer are other possibilities.

The Personal Beacon^{7,8} multiplier board that I described several years ago will also work. It uses 0.062 inch thick PC board, so we know it will radiate – it wasn't a problem, since beacons are supposed to radiate. However, as an LO, it should be enclosed in a separate metal box to prevent unwanted LO radiation.

To reduce LO radiation from the PC board, I tried the Personal Beacon on thinner 1/32" PC board like the transverter, shown on the right in Figure 15. It works just as well as the original, but with minimal radiation – anything more than perhaps 3/4" away from the circuit has no effect. With an input frequency of 1136 MHz, it provides +7 to +10 dBm output at 10224 MHz, perfect for the transverter. Required input power is around +2 to +6 dBm, which is the output level of the apollo-32 synthesizer from Down East Microwave⁹.

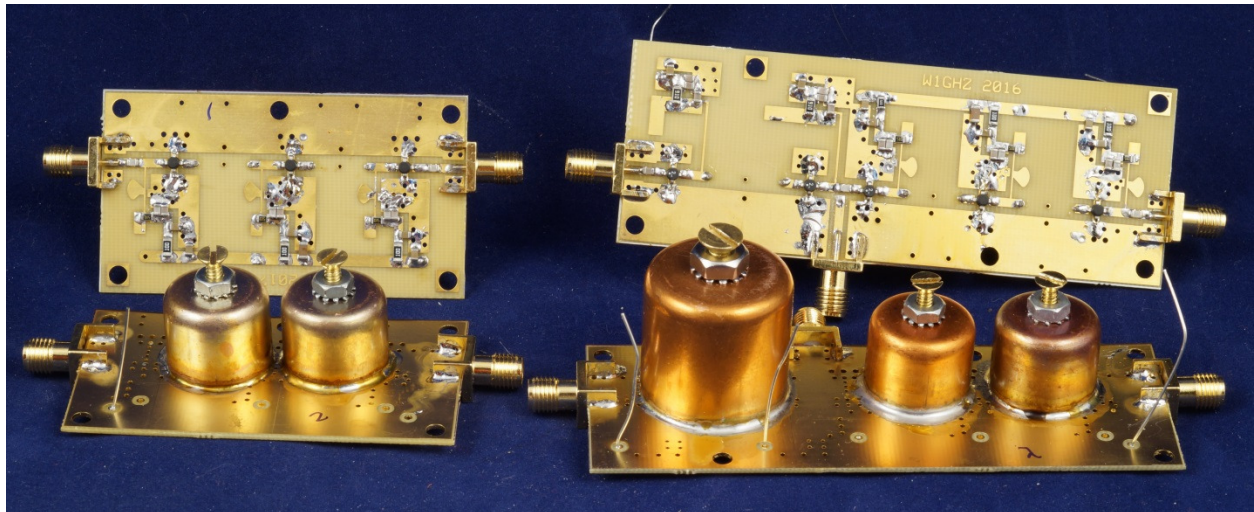

Figure 15 – Frequency Multiplier boards for 10 GHz Transverter

Also shown in Figure 15, on the left, is a smaller multiplier board, also on 1/32" dielectric PC board. This board only multiplies once, by two, three, or four times, from a higher frequency synthesizer like some of the inexpensive ones found on ebay. The schematic diagram is exactly the same as the three transmit amplifier stages of the transverter – over driving the first stage at a lower frequency causes it to generate harmonics.

Don Twombly, W1FKF, put together a 10 GHz Transverter with the small frequency multiplier board in a compact package, shown in Figure 16.

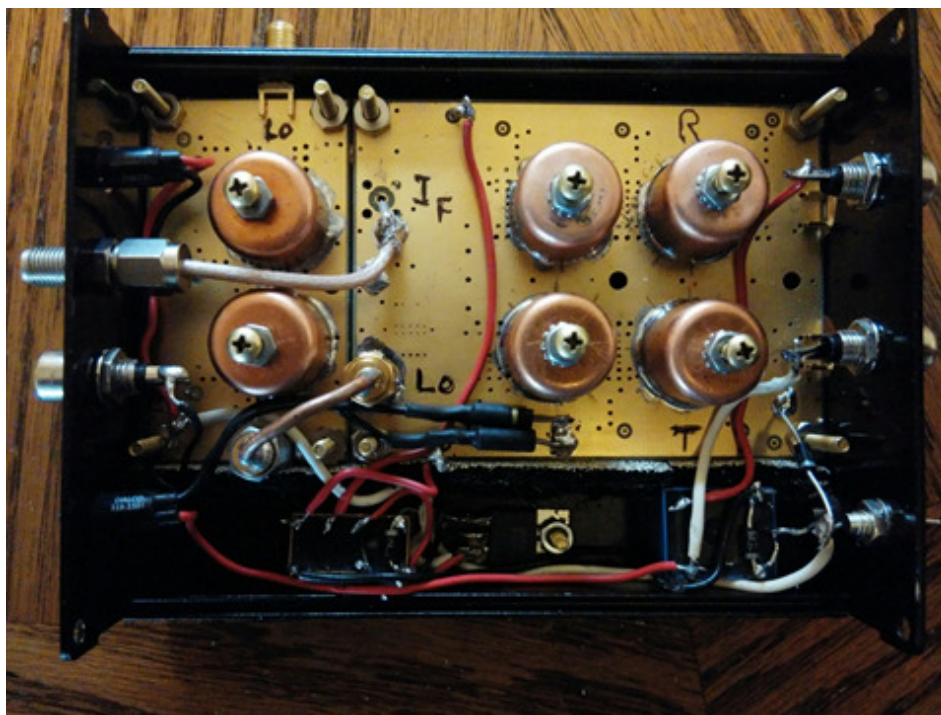

Figure 16 – Complete 10 GHz Transverter with Frequency Multiplier by W1FKF

Summary

It has taken a long time and several attempts, but this transverter should help folks get on 10 GHz without a large expense. The price instead is do-it-yourself: soldering, tuning, and learning.

References

1. Paul Wade, W1GHZ, "A Simple Low-cost 5760 MHz Transverter for the Rover," *Proceedings of Microwave Update 2016*, ARRL, 2016, pp. 110-122.
http://www.w1ghz.org/MBT/5760_MHz_Transverter_Update_March_2016.pdf
2. http://w1ghz.org/small_proj/MBT/multiband.htm
3. Paul Wade, W1GHZ, "Pipe-Cap Filters Revisited," www.w1ghz.org/new/Pipe-cap_Filters_Revisited.pdf
4. www.minicircuits.com
5. www.digikey.com
6. Paul Wade, W1GHZ, "A Single-Board Transverter for 10 GHz," *Proceedings of the 25th Eastern VHF/UHF Conference*, ARRL, 1999, pp. 381-396.
7. Paul Wade, W1GHZ, "A Personal Beacon for 10 GHz,"
http://www.w1ghz.org/small_proj/Beacon_10GHz.zip
8. Paul Wade, W1GHZ, "Update – A Personal Beacon for 10 GHz,"
http://www.w1ghz.org/small_proj/Update-10GHz_Personal_Beacon.pdf
9. <http://www.downeastmicrowave.com/product-p/a32.htm>

Appendix – 2024 Update

The 10 GHz transverter has been built and put on the air by a number of hams, and we have learned a bit thanks to their suggestions. A few component changes are suggested as shown in the updated schematic below:

- The resistors in the power divider, R1, are changed from 33 ohms to 18 ohms. This provides a better 50-ohm match for the mixer, and reduces loss a bit.
- The series blocking capacitors, C1, are changed from 5 pf to the 1 pf capacitor suggested in the parts list below. This improves output by perhaps a dB, and probably provides similar receive improvement. More expensive 1 pf ATC capacitors might even be slightly better. The other C1 capacitors, in the bypassing area, are less critical, but the new 1 pf capacitors may also be used if you are ordering parts anyway.

10368 MHz TRANSVERTER

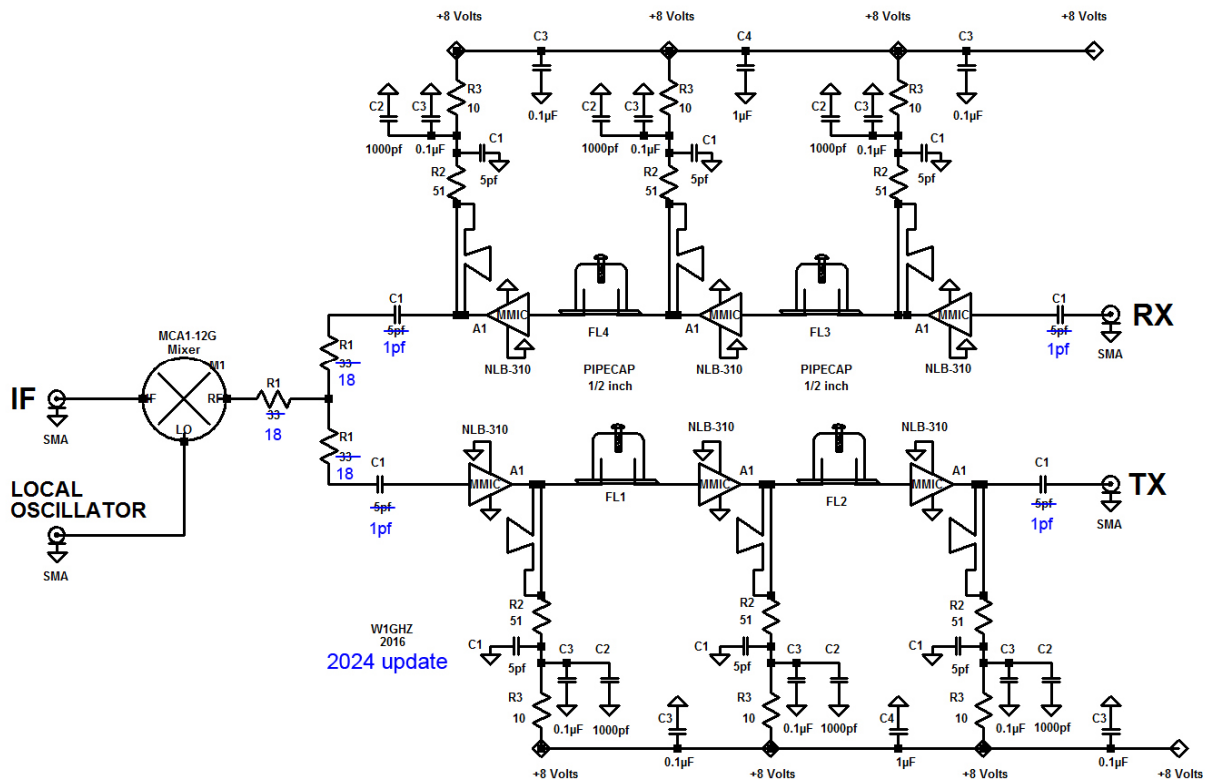

Updated schematic with 2024 changes

Suggested Parts List for 10 GHz Transverter and Multiplier Boards

<u>Designator</u>	<u>Value</u>	<u>Mouser #</u>
C1	1 pf	581-06035U1R0BAT2A
C2	1000 pf	80-C0805C102K2GEAUTO
C3	0.1 uf	80-C0805C104K1REAULR
C4	1 uf	581-KGM21AR71E105KL
R1	18	660-RK73B2ATTD180J
R2	51	660-RK73B2ATTDD510J
R3	10	660-RK73B2ATTDD100J
A1	NLB-310	772-NLB-310
M1	MCA1-12G+	139-MCA1-12G+
SMA	12.4 GHz	960-EMPCB.SMAFSTJBHT

Notes:

1. The NLB-310 MMICs are becoming obsolete. Order enough soon!
2. The SMA on the IF port can be a cheap Chinese one.
3. The SMD capacitors and resistors are much cheaper in quantity. Order at least 10 and have some spares. You will probably lose some of these small parts.