

Multiband Microwave Transverters for the Rover

Simple and Cheap

Paul Wade W1GHZ ©2008
w1ghz@arrl.net

update 16 April 2008

Operating on multiple microwave bands in VHF contests will greatly enhance a score, as well as lending some excitement to quiet periods. This is particularly true for rover operation. Hilltopping with the microwave gear can also be a lot of fun between contests. However, buying equipment for many bands is not only a considerable expense, but also results in a lot of gear to carry around.

The system described here is an attempt to reduce the cost, size, and power requirements for operation on several microwave bands, as long as one is willing to do a bit of soldering. Many of us in northern latitudes find that a good part of the year is better suited to soldering than to hilltopping.

Design Philosophy

The basic design philosophy is that today, *gain is cheap*. Traditional microwave engineering worked to minimize losses because gain was hard to come by. We don't need to use exotic parts to keep losses down, because MMICs provide cheap gain – less than 25 cents per dB – so if we give up a dB to use an ordinary, readily available part rather than an expensive microwave part, it is a reasonable tradeoff. We start with the PC boards, using ordinary epoxy-fiberglass board rather than Teflon-based microwave material. The loss is perhaps a dB per inch higher, but fabricated boards are readily available without exorbitant lot charges. For capacitors we use ordinary chip capacitors, at a few cents each, rather than microwave capacitors costing a dollar each. The final tradeoff is to try and limit the number of different part values, using multiples of each value rather than many different values, since prices are much more reasonable in quantities of 100. Finally, commodity parts that will continue to be readily available are preferred.

Multi-band Strategy

The heart of this multi-band system is a single oscillator source providing the local oscillator (LO) to transverters for several microwave bands. This not only reduces the power needed for LO, allowing the oscillator to be powered continuously for better stability, but also enables better compensation for frequency errors, since the frequency error on one band each band is a simple integer multiple of the base oscillator frequency. Thus, once a frequency offset is found on one band, it may be quickly predicted and compensated on other bands.

The microwave LO source frequency is at 720 MHz, which is multiplied to provide an LO for 1296, 2304, 3456, and 10368 MHz, with normal 2-meter and 432 MHz IF frequencies. Figure 1 shows the overall frequency scheme; each transverter includes the final multiplication needed for a particular band. Harmonics of 720 MHz are conveniently occur 144 MHz away from 1296, 2304, and 3456 MHz, and 432 MHz away from 10368 MHz, except that all but 2304 MHz are above the activity frequency. Thus, the calling frequency lands at about 143.9 MHz or 431.9 MHz, with inverted SSB. This is a minor inconvenience, since most of the common IF transceivers can be readily modified to tune slightly out of the amateur band. Many of us have been tuning upside-down on some of the microwave bands anyway, using surplus “brick” oscillators for the LO, and accurate frequency readout is only a coincidence.

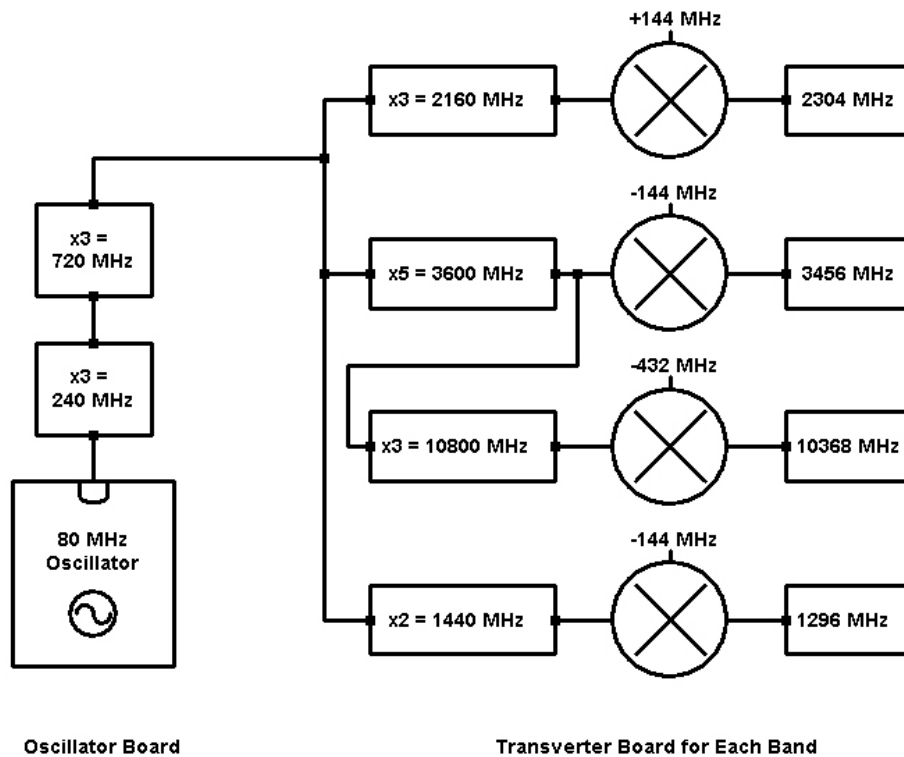

Figure 1. Multi-band Frequency Scheme

Part 2: Oscillator Board

The oscillator board, shown in Figure 2, starts with an inexpensive 80 MHz computer oscillator which is multiplied up to 720 MHz. I used similar oscillators in my 222 MHz transverter¹, and found them to be stable, reliable, and very close to the nominal frequency. Stability is enhanced by double voltage regulation – the oscillator is powered from a 5-volt 3-terminal regulator, while the rest of the system is powered from a larger 8-volt regulator. However, the frequency can't be trimmed, so there will always be a small frequency offset. If you don't know how to use that big knob on your radio, this isn't for you.

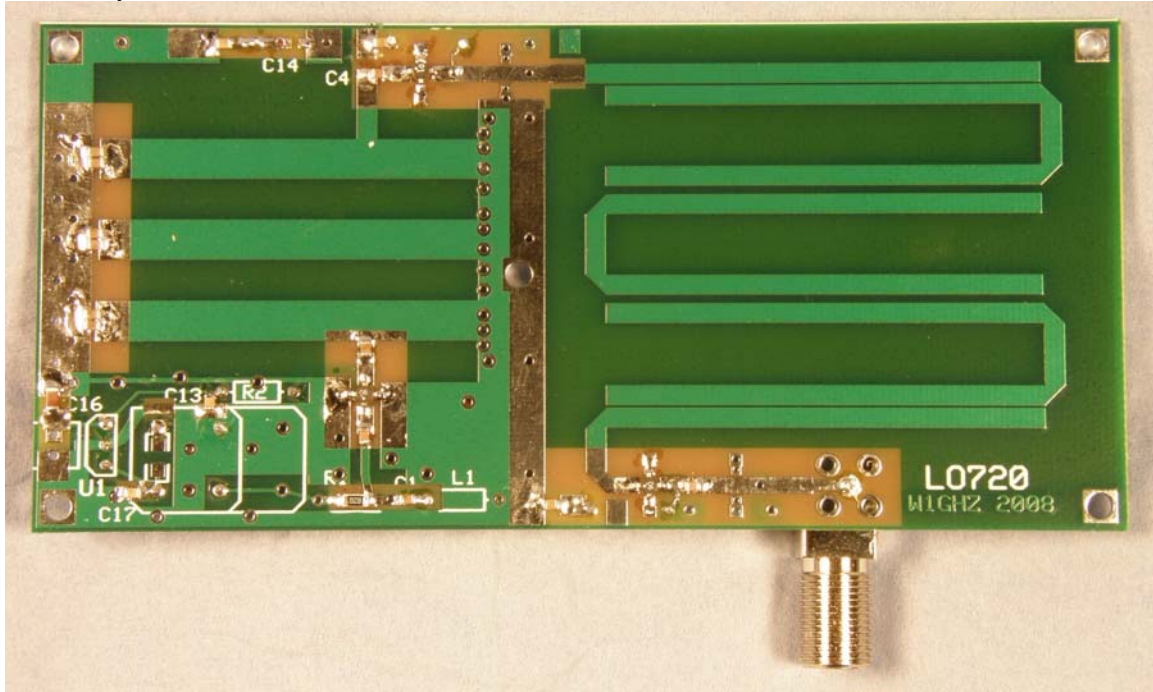

Figure 1. 720 MHz Local Oscillator Board (2008 version)

All of the RF components are on the filter side of the board, while all the other parts, even the oscillator can, and the power distribution wiring, are on the ground plane side of the board shown in Figure 3. The output connector pattern is for an SMA, but in this copy a Type-F connector is used instead to allow use of inexpensive CATV power splitters for LO distribution.

The schematic diagram of the oscillator board is shown in Figure 4. Since the oscillator output is a square wave, it is rich in odd harmonics, particularly the third harmonic. I used the same technique as the 222 MHz transverter – remove the 80 MHz fundamental with a simple diplexer, amplify the harmonics with MMIC A1, then filter to pick out the desired third harmonic, 240 MHz.

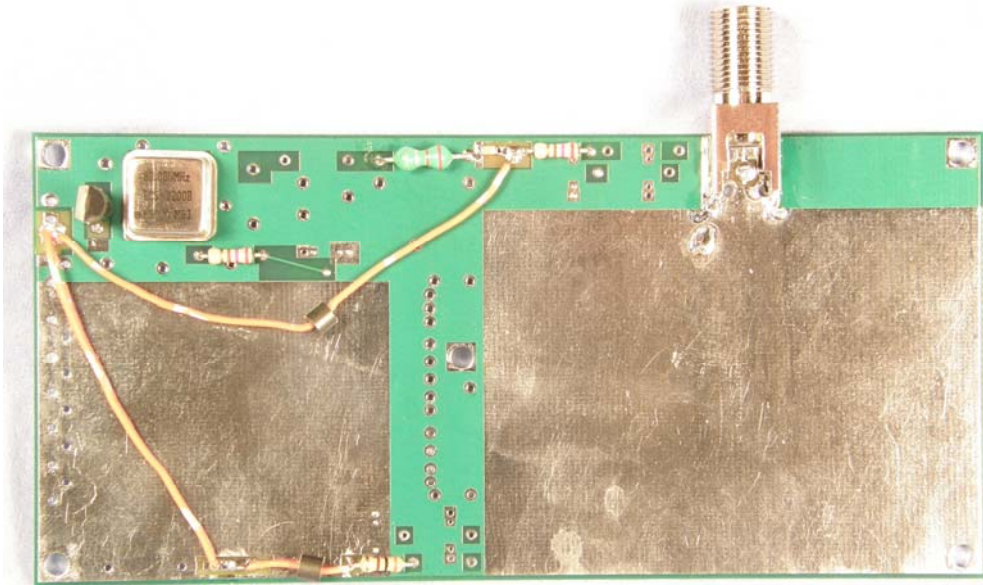

Figure 2 Ground plane side of 720 MHz LO board

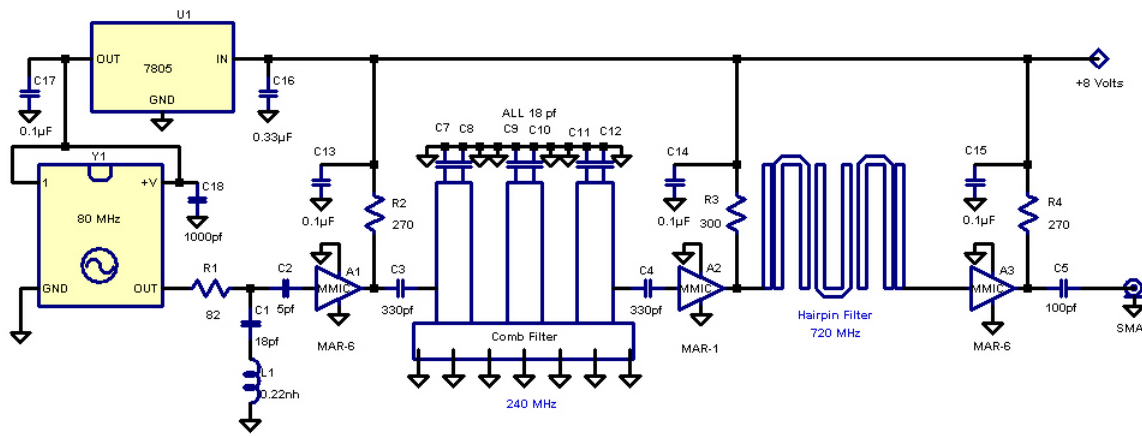

Figure 3. 720 MHz Local Oscillator Schematic

The filter at 240 MHz was the most difficult part of designing this project. I had originally intended to try retuning a 220 MHz Toko helical filter, but found that they are no longer in production. No good alternative is readily available, so I considered printed filters. Hairpin filters like those in older “no-tune” transverters work well, but would take up a lot of PCB real estate at this frequency. I used the Filter Design Wizard in **Ansoft Designer SV²** (free Student Version) to investigate some alternatives. One promising filter was a combline – parallel $\frac{1}{4}\lambda$ resonators, capacitively shortened. I started with the design from the Wizard and put in real capacitor models – chip capacitors have inductance and resistance also. The ESR (Equivalent Series Resistance) and ESL (inductance) were found using the **SpiCap3** utility from AVX³. Unfortunately, the resistance of ordinary chip capacitors was too high, so the filter had high loss and poor passband shape. Perhaps good microwave capacitors would be better – but then it occurred to me: resistance can be reduced by paralleling resistors. I tried two smaller

capacitors in parallel and the simulated filter improved, with lower loss and a better shape.

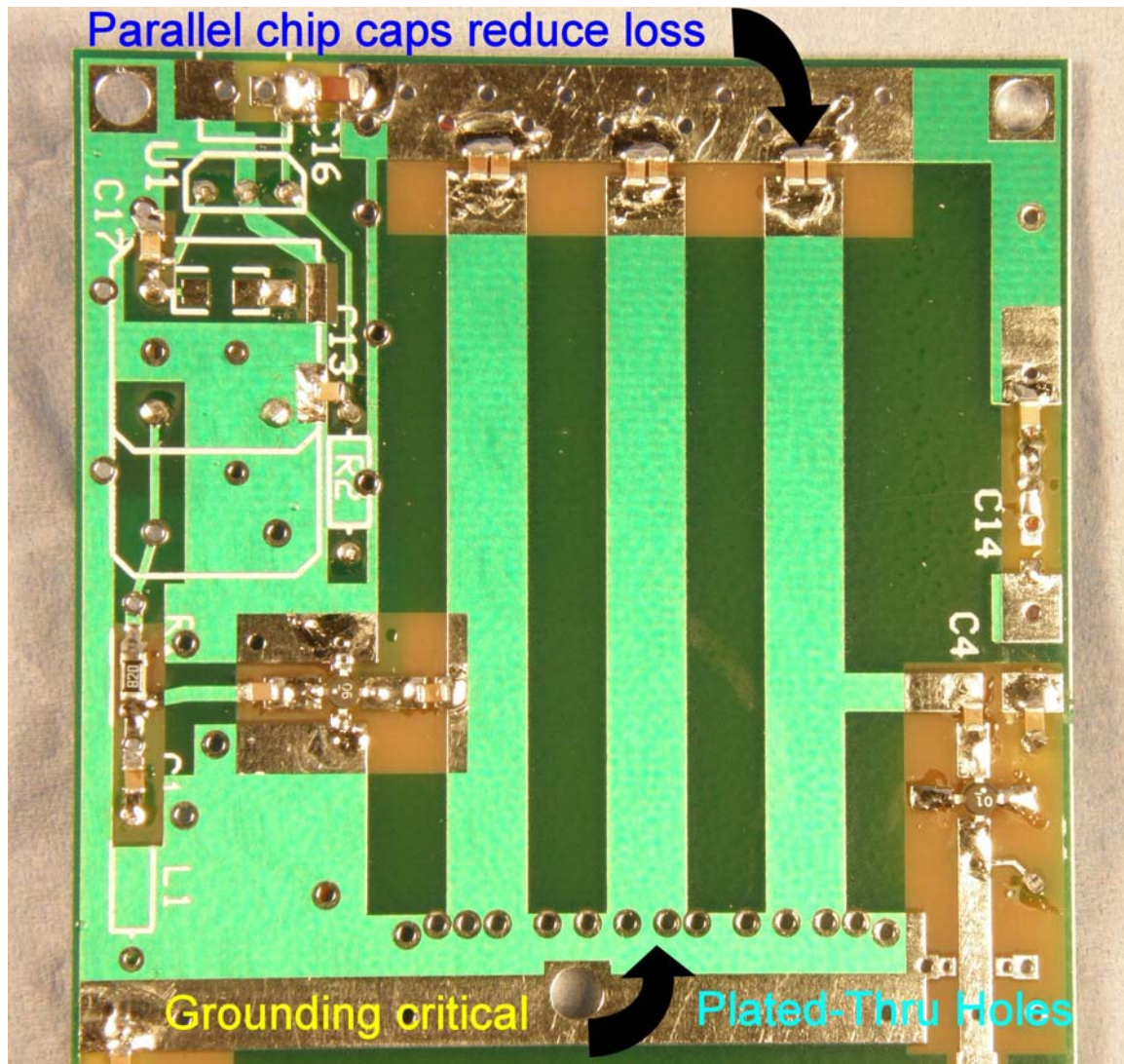

Figure 4 – 240 MHz Filter end of LO board

The other problem with a combline filter is that good grounding is needed at both ends, unlike the hairpin filters. Plated-thru holes (PTH, also called vias in the PCB industry) provide a good, low-inductance path to ground, as shown in Figure 5. The full (expensive) version of **Ansoft Designer** will simulate an actual PCB layout, so I drew a trial layout, including the multiple plated-thru holes for grounding. The filter still appeared to work well, but the capacitance needed for each resonator was about 33 pf, vs. 42 pf on the original design, due to the (small) inductance of the PTHs and chip capacitors. I figured that some parallel combination of standard capacitor values between 15 and 22 pf would put the filter on frequency.

Using the free PCB layout software from ExpressPCB⁴, I transferred the filter layout onto an oscillator board. When I finally got some prototype boards, I cut one up to test the filters. I tested the filter first with 33 pf microwave capacitors; it worked as predicted, with about 5 dB of loss. The passband covered 240 MHz, but the center frequency was a bit higher. Then I switched to cheap (less than \$.07 each) chip capacitors from Digikey, using two small 18-pf caps (0805 size) in parallel on each resonator. It worked perfectly, as shown in Figure 6, centered around 240 MHz, with perhaps slightly lower loss than with the microwave capacitors. Note that larger (1206 size) chip capacitor packages have higher ESR and ESL, so will probably not work as well. Even smaller (0603 size) ones have lower predicted resistance, so the loss should be slightly lower, but they are harder to handle.

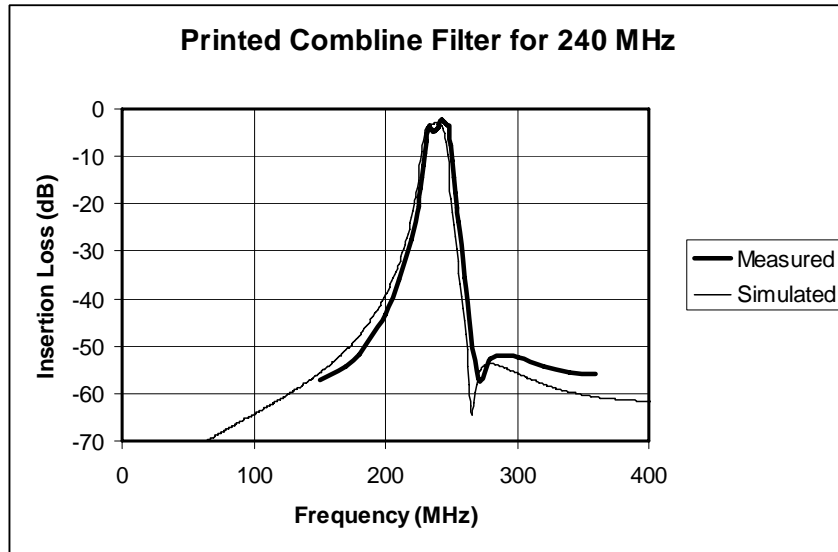

Figure 5

It might have occurred to you already that this filter is not fixed at one frequency, but is usable over some range by changing capacitors. The calculated tuning curve is shown in Figure 7. Feel free to give it a try if you need a different frequency. I wouldn't recommend the steep part of the curve at the left.

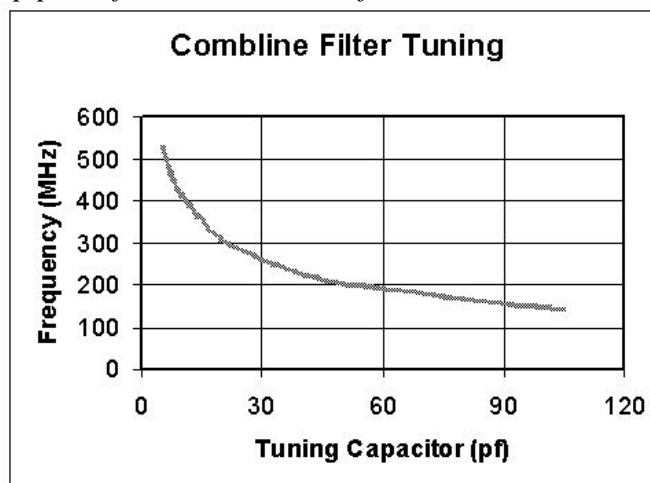

Figure 6

The combine filter is followed by a x3 multiplier, A2, an overdriven MMIC. There is a test point after the filter – use C3 to temporarily connect the test point rather than the MMIC, and slip an SMA connector over the test point. You should measure about +5 dBm at 240 MHz at the test point. This is enough power to overdrive a MAR-1 and produce enough distortion to generate the third harmonic. The MAR-1 current is set by the bias resistor, R3, for maximum output at 720 MHz, measured after the next filter. You may fiddle this resistor value if you have a need to adjust something.

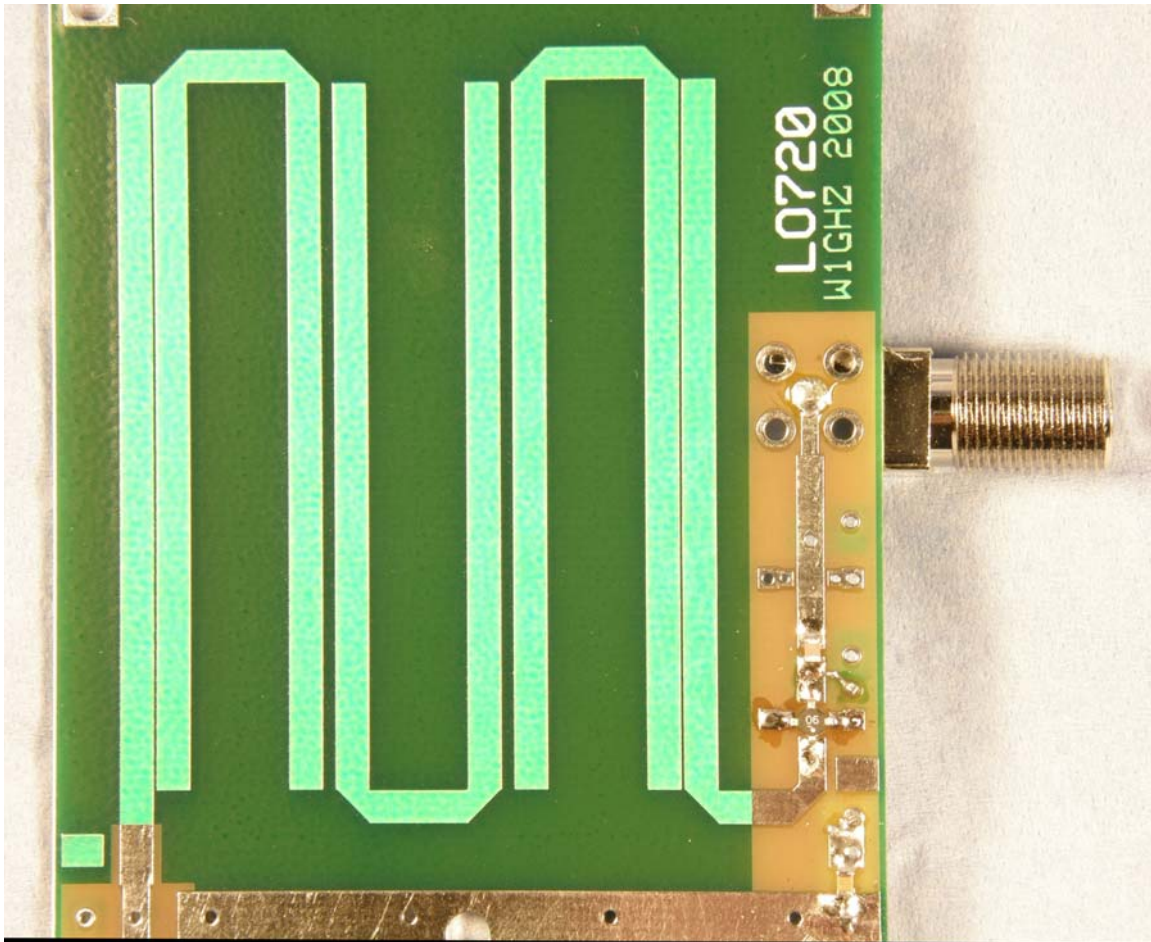

Figure 7 - 720 MHz Filter end of LO board

The multiplier output passes through the hairpin filter at 720 MHz. This filter has edge-coupled input and output, unlike the usual tapped-input configuration. Edge coupling produces sharper skirts and better stopband rejection below the operating frequency, ideal for eliminating fundamental and 2nd harmonic outputs from the multiplier. A plot of the 720 MHz filter performance is shown in Figure 9. The edge coupling requires very tightly controlled spacing of the lines, but within the capabilities of ExpressPCB.

There is another test point after the hairpin filter. Use a jumper to connect the testpoint before A3 is mounted. Typical signal level after the hairpin filter is -16 dBm at 720 MHz. This testpoint is probably unnecessary since the MAR-6 amplifier has predictable performance. A3 brings the output level up to around +5 dBm, which is what we need to

drive the transverter. All the other harmonics of 240 MHz are at least 33 dB down except 1440 MHz, which is less than 20 dB down.

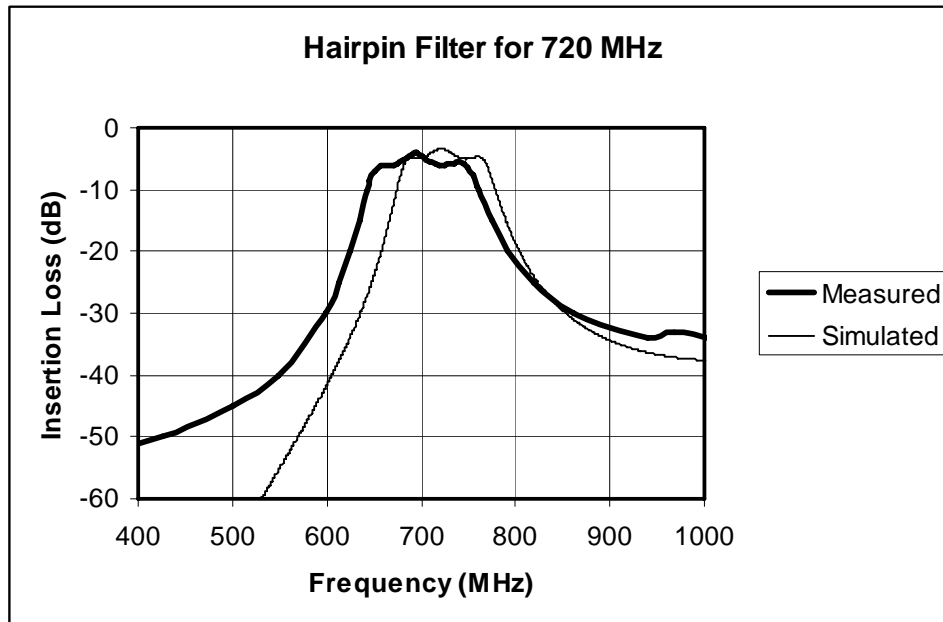

Figure 8

If, for some reason, you desire more output power, a bit of work with an X-Acto knife will make spaces (a blocking capacitor and bias resistor are needed) in the transmission line following A3 for an additional MMIC amplifier; the grounding pads are already there. An MSA-11 would make a good higher power stage.

One final note about the oscillator, since the ones I used may not be available forever, but 80 MHz seems to be a popular frequency. To try some alternatives, I bought a couple of batches of 80 MHz oscillators on Ebay. One batch apparently needs a negative voltage, so was tossed after smoking a couple. The other batch has a softer waveform, less like a square wave, so there is less third harmonic in the output. The level was about 10 dB low after the 240 MHz filter. I added a low-gain MMIC, a MAR-7, in place of A2 before the MAR-1 multiplier to bring the level up. Again, the grounding pads are in place for an extra stage – just cut an opening in the transmission line after A2 with an X-Acto knife. The MAR-7 bias resistor was 180 ohms.

The whole LO board requires about 1 watt of power, 12 volts at 80 milliamps, so it could be run continuously for better stability. For backpackers, all but the oscillator could be powered down. One LO board could be used for multiple transverters, further reducing power needs. For more flexibility, they are cheap enough to use a separate LO board for each band – a complete LO board probably costs less than a crystal for a surplus “brick” oscillator.

Part 3: Transverter for 2304 and 3456 MHz

When I finished my 5760 MHz single-board transverter⁵ back in 1997, it occurred to me that it would work well on 3456 with retuned pipe-cap filters, if the mixer were changed. However, moving the mixer down in frequency would require more real estate, and real estate is expensive on Teflon PC board.

Sometime later, it occurred to me that a larger pipe-cap might cover both 2304 and 3456 MHz, so one transverter layout might work on both bands, if a mixer could cover both bands. I had a couple in the junkbox won as prizes at a VHF conference. A visit to the Minicircuits⁶ website showed these to be a rather expensive model, but several inexpensive mixers would also do the job. I chose the ADE-18W as a reasonably priced (\$3.95) one which looked like it could be hand-soldered – some of the other surface mount models don't have accessible leads.

The next question was whether it would all fit on an ExpressPCB Miniboard, the cheapest source for manufactured PC boards – \$59 for three boards. The Miniboard only comes in one size, 2.5" x 3.8". Working with the free ExpressPCB software, I was able to fit four 1" pipe-caps on the board, shown in Figure 10. The 5760 board has five, but also has separate transmit and receive mixers, each with a filter. By using a common mixer, the number could be reduced to four.

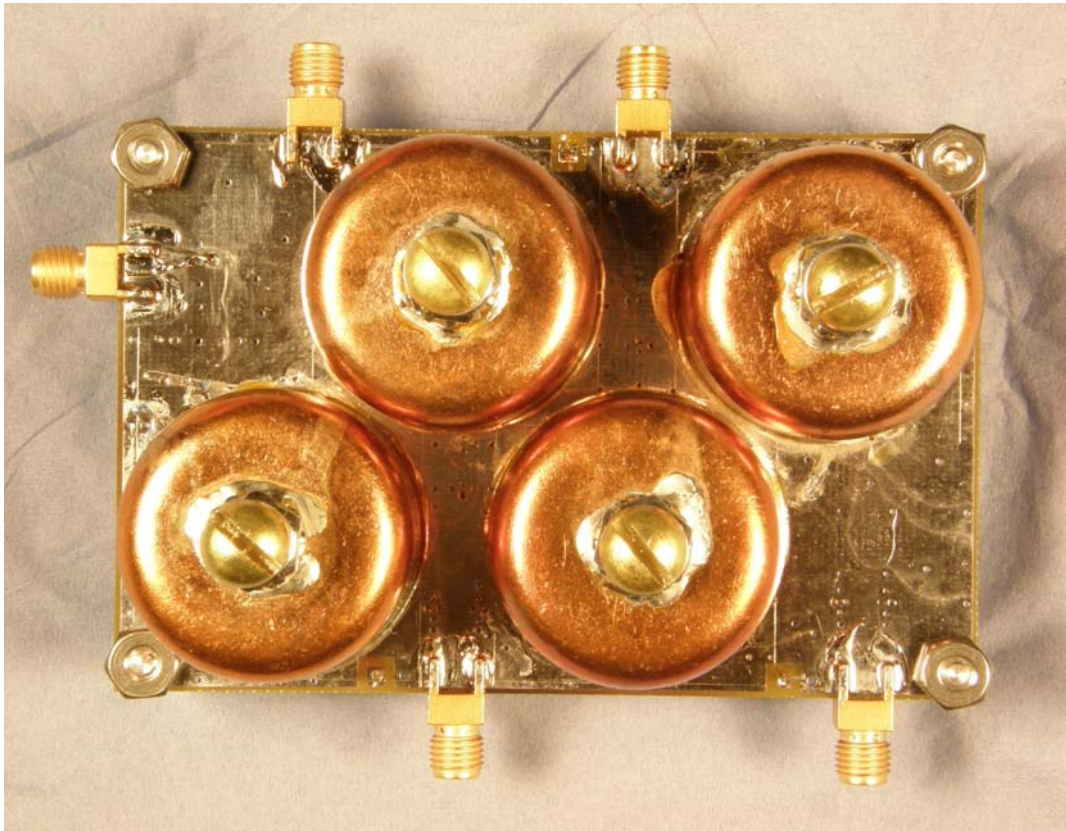

Figure 10. Pipe-cap Filter Side of Transverter Board

The schematic diagram of the transverter board is shown in Figure 11. Two of the pipe-cap filters are used to complete the LO chain, taking the 720 MHz output from the LO board and multiplying one more time. The multiplier is either x3, to 2160 MHz, or x5, to 3600 MHz, using an overdriven ERA-2 MMIC as the multiplier, A4. I also tried a MAR-1 for A4, but didn't get enough output, even as a x3 multiplier. Following the multiplier is a pipe-cap filter, another MMIC, and a second pipe-cap filter, to provide a clean LO signal to the mixer. The second MMIC, A5, is an ERA-2 at 3600 MHz, but a lower gain ERA-1 is sufficient at 2160 MHz. Note that there are only two resistor values and four capacitor values on the board, all ordinary chip components.

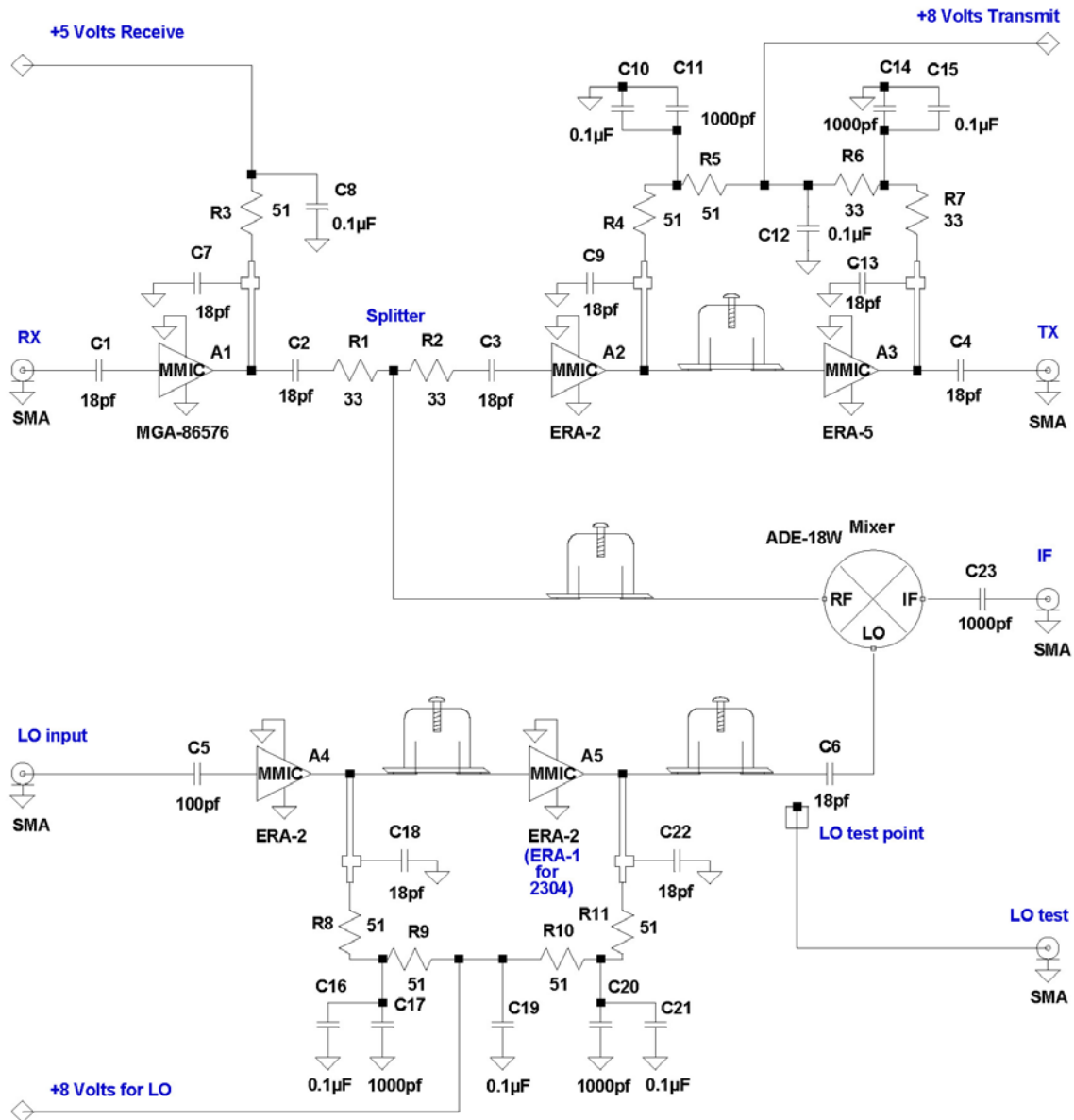

Figure 11. Schematic of Transverter Board for 2304 and 3456 MHz

A single mixer, the ADE-18W, is used for both transmit and receive. The IF port is brought out to a connector, to provide 144 MHz output on receive and input on transmit. The transmit IF level should be no more than 0 dBm at 144 MHz.

The output of the mixer goes to the third pipe-cap filter to remove the image and any LO leakage, then to a resistive splitter to separate transmit and receive. My first prototype used three probes in the pipe-cap for separate transmit and receive, a trick that K2CBA used in his Easyverter⁷. It worked, but getting the probes matched proved to be touchy, and the loss was no better than the resistive splitter. Two extra resistors are easier than something requiring adjustment.

The transmit path has an ERA-2 amplifier, A2, the fourth pipe-cap filter, and an ERA-5 power amplifier, A3. The receiver uses a low-noise GaAs MMIC, the MGA-86576, at A1 to overcome the loss of the mixer and filter. Noise figure should be more than adequate for a low power station. The front-end is wide open, so a real filter is suggested for operation on mountaintops or near cell towers.

Assembly and Tuneup

The first step in assembly is to solder the pipe caps to the board, after drilling and tapping the 10-32 screw holes in the top of the caps. Each pipe-cap location has a hole at the center, halfway between the probe locations. I scribe lines on the bare board 5/8" away from the center hole, making a square to line up each pipe cap. Then I put a bit of paste flux on the rim of each cap, place the caps in position, and put a ring of wire solder around the base of each cap. I solder the caps one at a time, holding the one being soldered in position with a screwdriver while heating the top of the cap with a hot air gun. The copper conducts the heat down to the board; when the joint reaches temperature, the ring of solder melts and flows around the base of the cap, without overheating the board. As soon as the solder flows, remove the heat, let it cool until the solder solidifies, then move on to the next cap. A torch could also be used, but tends to oxidize the copper.

All other components are surface-mount, on the side of the board opposite the pipe caps, shown in Figure 12. I recommend "No-clean" solder like Kester 245, preferable 0.020" in diameter or smaller – then we don't have to worry about cleaning liquids getting into the pipe caps and other unwanted places. Tin-lead solder works fine, and there is no reason for hams to worry about lead-free solders.

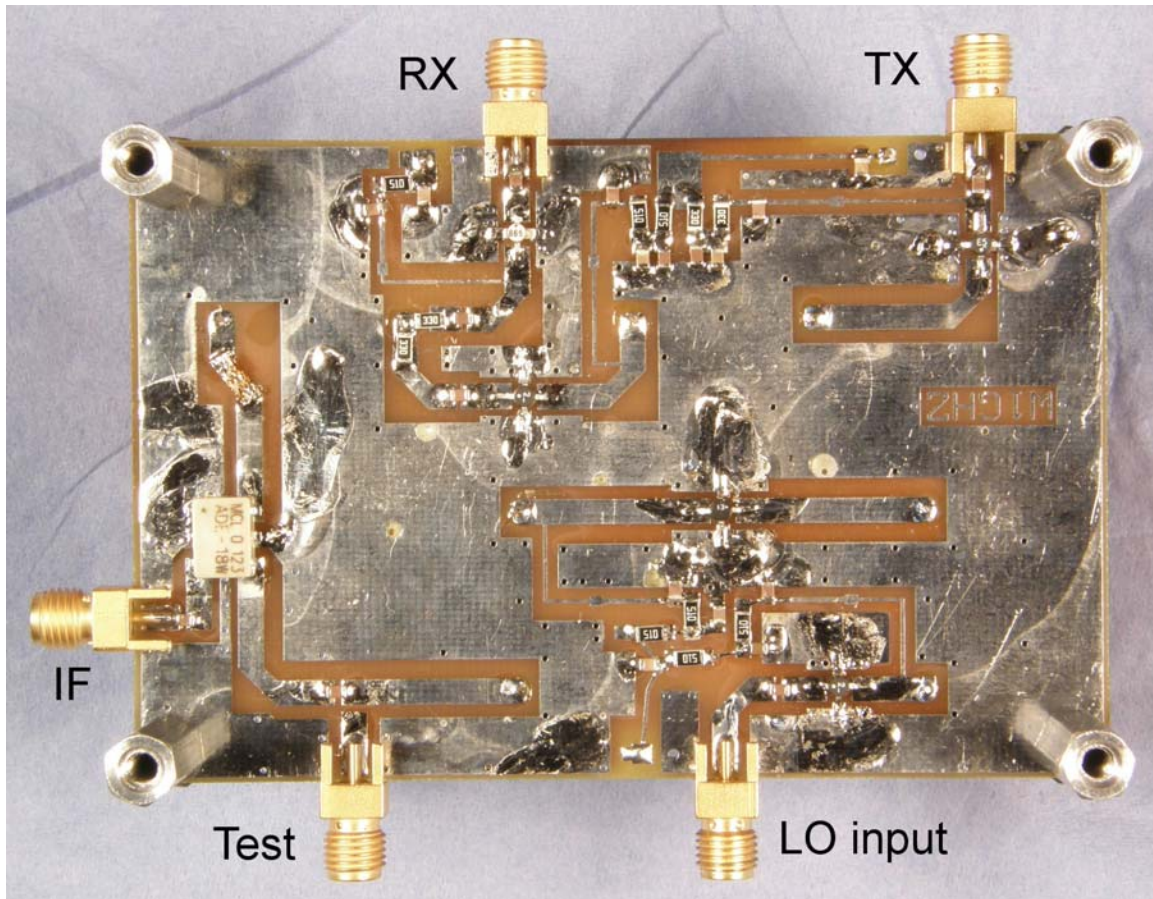

Figure 12. Component side of transverter board, configured for 2304 MHz

Next, decide which band the transverter is to operate on. Two things determine the operating frequency: the depth of the tuning screws in the pipe-cap filters, and the length of the quarter-wave printed choke lines on the MMIC amplifiers. The electrical length is determined by the position of the bypass capacitors – these are the same cheap 18 pf chip capacitors used for the 240 MHz filter. For 2304 MHz, the full length of the choke line is used, so the capacitors go at the end, while for 3456 MHz, the capacitors should be placed on the wide area at about 2/3 of the length. Figure 13 is a closeup of the transmit output amplifier, A5, illustrating the capacitor placement for each band.

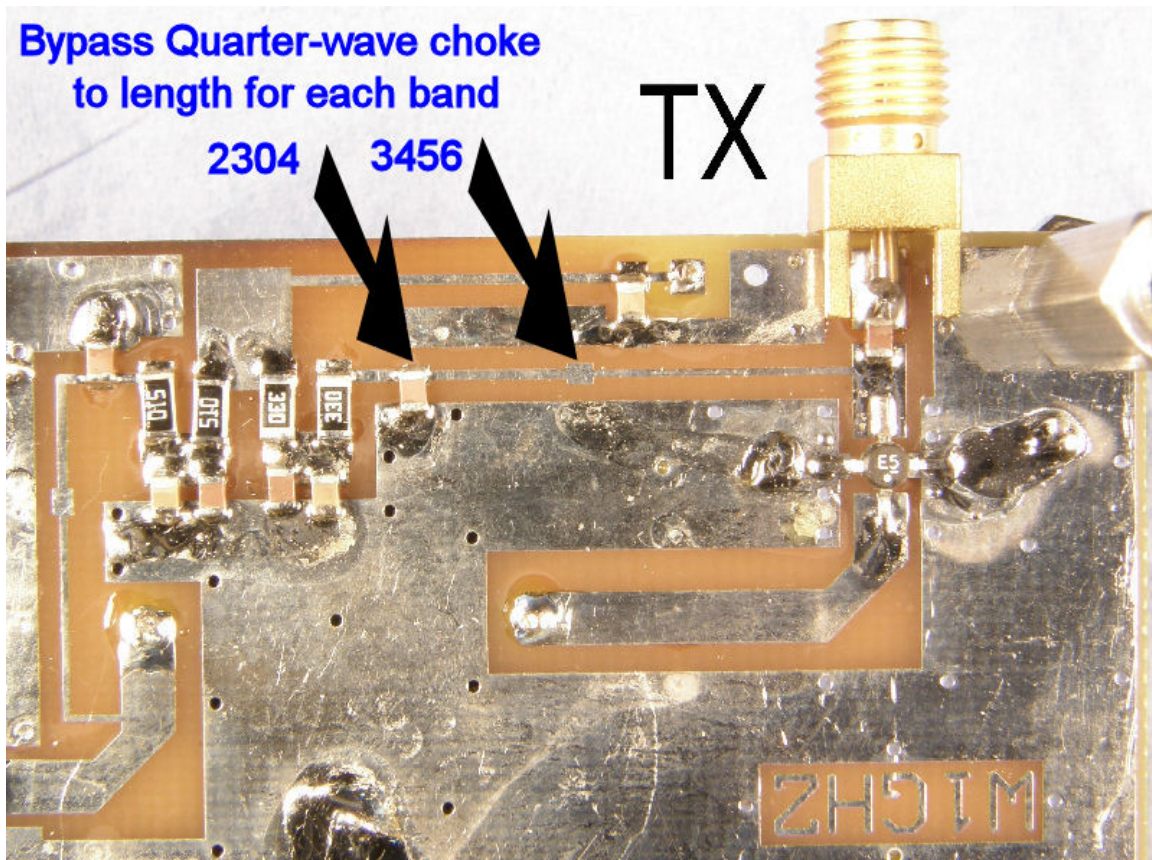

Figure 13 Closeup of final Transmit amplifier, illustrating capacitor placement for each band.

The pipe-cap filter frequency is determined by the length of the tuning screw inside the cap, acting as a quarter-wave resonator. The probe length determines the selectivity of the filter – a short probe is lossy with critical tuning, while a long probe produces a broad response with poor selectivity.

A good length for the probes for both bands is about 0.375" inside the cap for 3456 MHz, and 0.400" for 2304 MHz. I measure the length on a straight piece of wire, add 0.060" for the board thickness, and notch the wire with a wirecutter. Then I insert the wire into the hole in the board until the notch is flush with the top surface, clamp it so it is perpendicular to the board, and solder it. Then I cut it off leaving a small nub to grab with tweezers if removal is necessary.

Tuneup is easier if components are added sequentially, starting with the LO section. A test point before the mixer allows tuning up the LO multiplier, using C6 to connect the SMA connector test pad. Connect the LO board to supply drive at 720 MHz. Start with the screws, 1.25" long brass screws, all the way in both pipe-caps, touching the board under the cap. Then back both screws out together until some signal is detected, and peak the output. This peak is at 2160 MHz. For 3600 MHz, continue backing the screws out past a second peak, at 2880 MHz, to a third peak at 3600 MHz. Output power should be +6 dBm or more at the test point, enough to drive the mixer. Figure 14 is a closeup of

the LO section of the board. Note that the capacitors are at the shorter location on the quarter-wave chokes – this copy is for 3456 MHz.

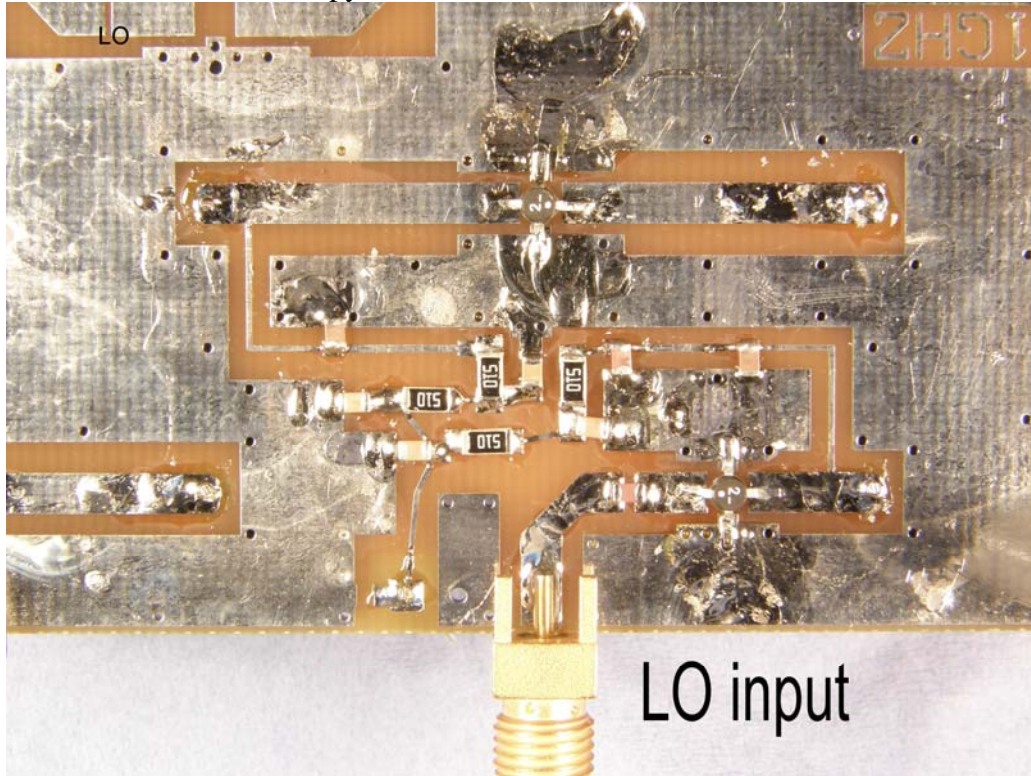
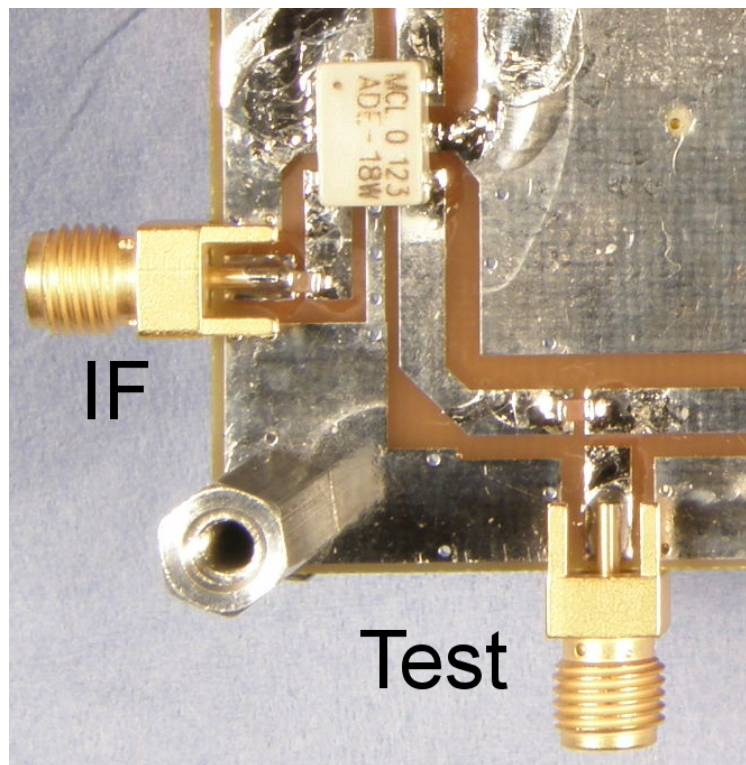

Figure 14 LO section of Transverter board

Then move C6 to connect the LO to the mixer. Solder the mixer down carefully, since the bottom is open (turn it over and admire the tiny transformers first), making sure to align it according to the picture, Figure 15. The mixer pipe-cap filter is tuned using the receive port as a test point, jumpering the MMIC location A1 with a wire as shown in Figure 16. Only the splitter resistor, R1, is needed at this point. With only the LO running, set the pipe-cap tuning screw the same height as the LO screws, then tune for a peak – this is at the LO frequency. Then apply 0 dBm at 144 MHz to the IF port. Now adjust the screw for a larger peak at the



RF frequency: 2304 MHz is higher than the 2160 MHz LO, so the screw should be backed out of the pipe cap to peak, but 3456 MHz is lower than the 3600 MHz LO so the screw should be tuned in to the cap for a peak. Tuning in the wrong direction will peak on the image frequency. Output from the receive port, being used as a test point here, should be on the order of -13 dBm. Check the output frequency if you can.

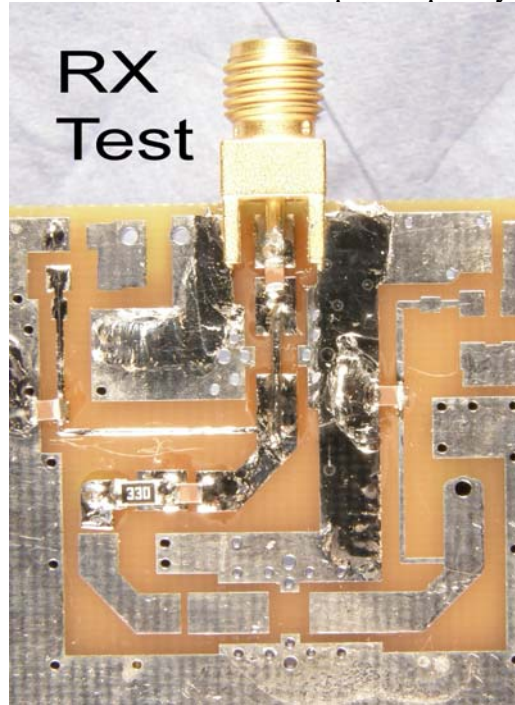
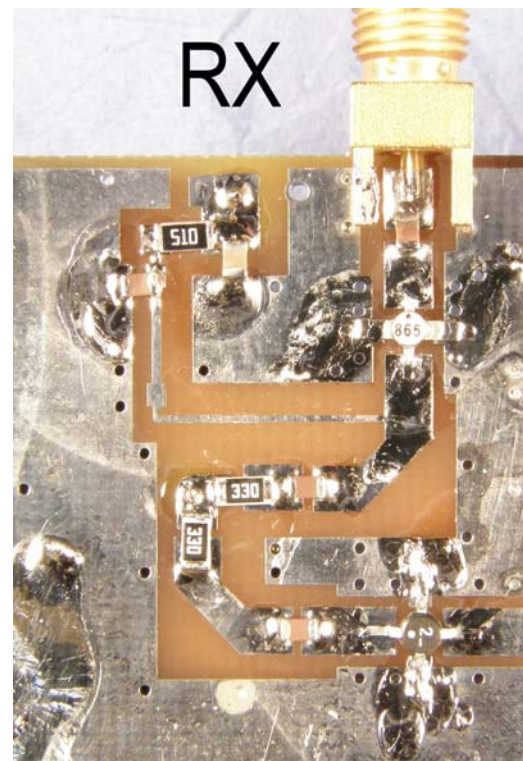

Figure 16. RX port used for filter tuneup, with wire jumper in place of A1

Remove the jumper wire from the A1 location, then assemble the transmit section. The driver stage, A4, is shown at the bottom of Figure 17, right, and the final stage, A5, in Figure 13. Set the final tuning screw to the same height as the mixer screw, power it up, and apply 0 dBm at 144 MHz to the IF port. Peak the pipe-cap tuning for maximum output, at least +10 dBm.

Finally, assemble the receive section as shown in Figure 17. Power the receive MMIC with about 5 volts (everything else runs on 8 volts) and connect a two-meter receiver to the IF. Stick a short wire in the SMA jack and tune in a signal – harmonics of my 1152 MHz marker are loud from across the basement. If you can measure noise figure, adjust the voltage to the receive MMIC to optimize – best noise figure should be somewhere between 5 and 7 volts.



Part 4 – 1296 MHz Transverter (work in progress)

The transverter for 1296 MHz has the same design philosophy as the transverters for higher bands – *gain is cheap*. At the lower frequency, it is even cheaper, since the older MAR series of MMICs provide adequate gain.

The schematic diagram for this transverter, in Figure 18, is similar to the others: LO input at 720 MHz from the common oscillator, an LO multiplier and amplifier, a mixer, and amplifiers for transmit and receive. Filters are 3-section printed hairpin filters rather than pipe-caps; the printed filters have a bit more loss, but don't require any tuning. Anyway, pipe-cap type filters would have to be nearly 2 inches high, assembled out of bits of pipe – the simplicity would be lost.

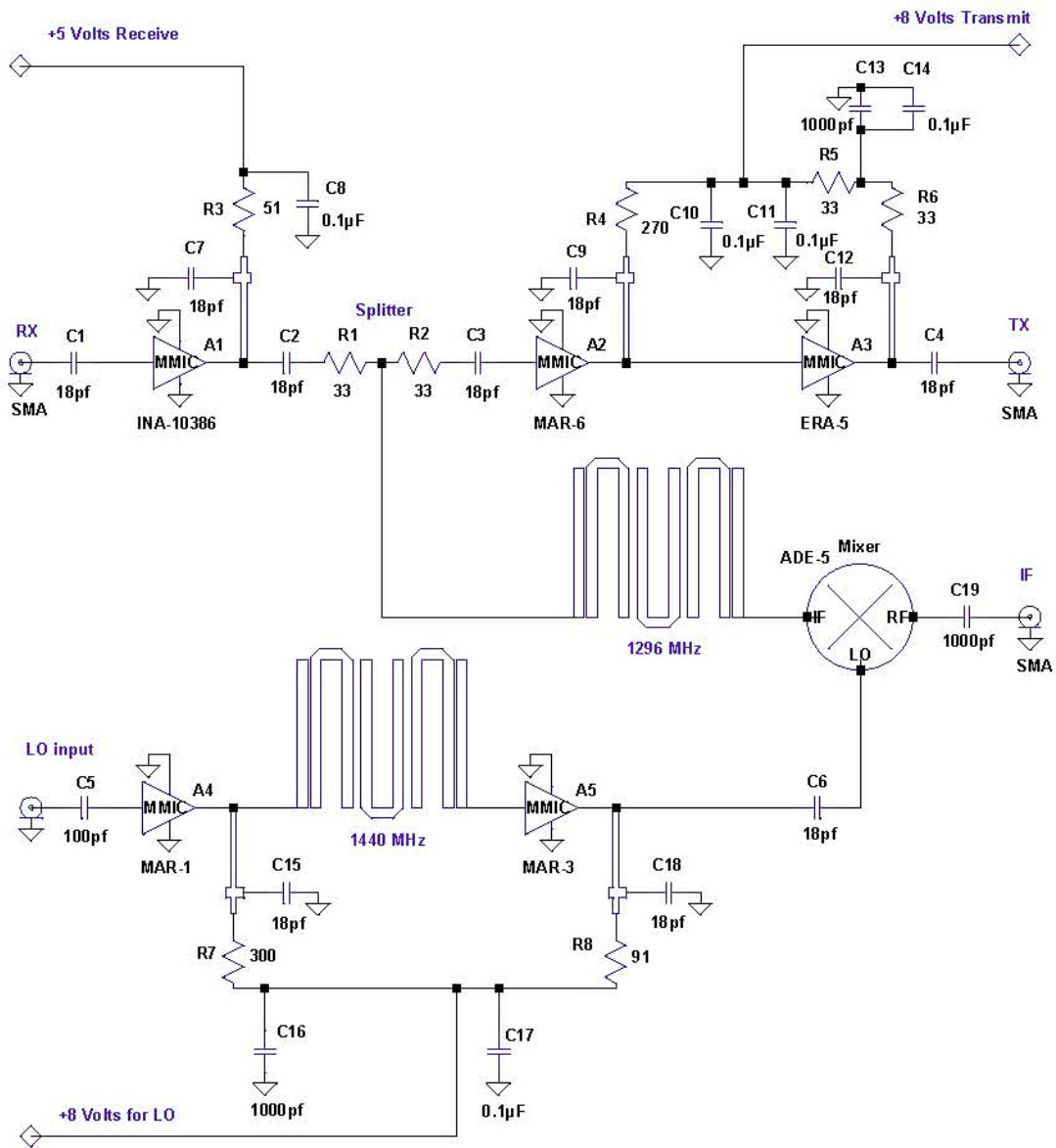

Figure 18 – Schematic Diagram of 1296 MHz Transverter

The transverter fits the Miniboard size limit from ExpressPCB, but there is only room for one LO filter and one RF filter. Figure 19 is a photo of the first prototype. Assembly is not difficult, and it worked with no problems. There is adequate LO power for the mixer, and drive for the LO multiplier is not critical – a reduction of 6 dB in drive reduces LO output by only 1 dB. Transmit power output is about 15 dBm, adequate for a simple rover rig, or more than enough to drive another transverter for a much higher microwave band.

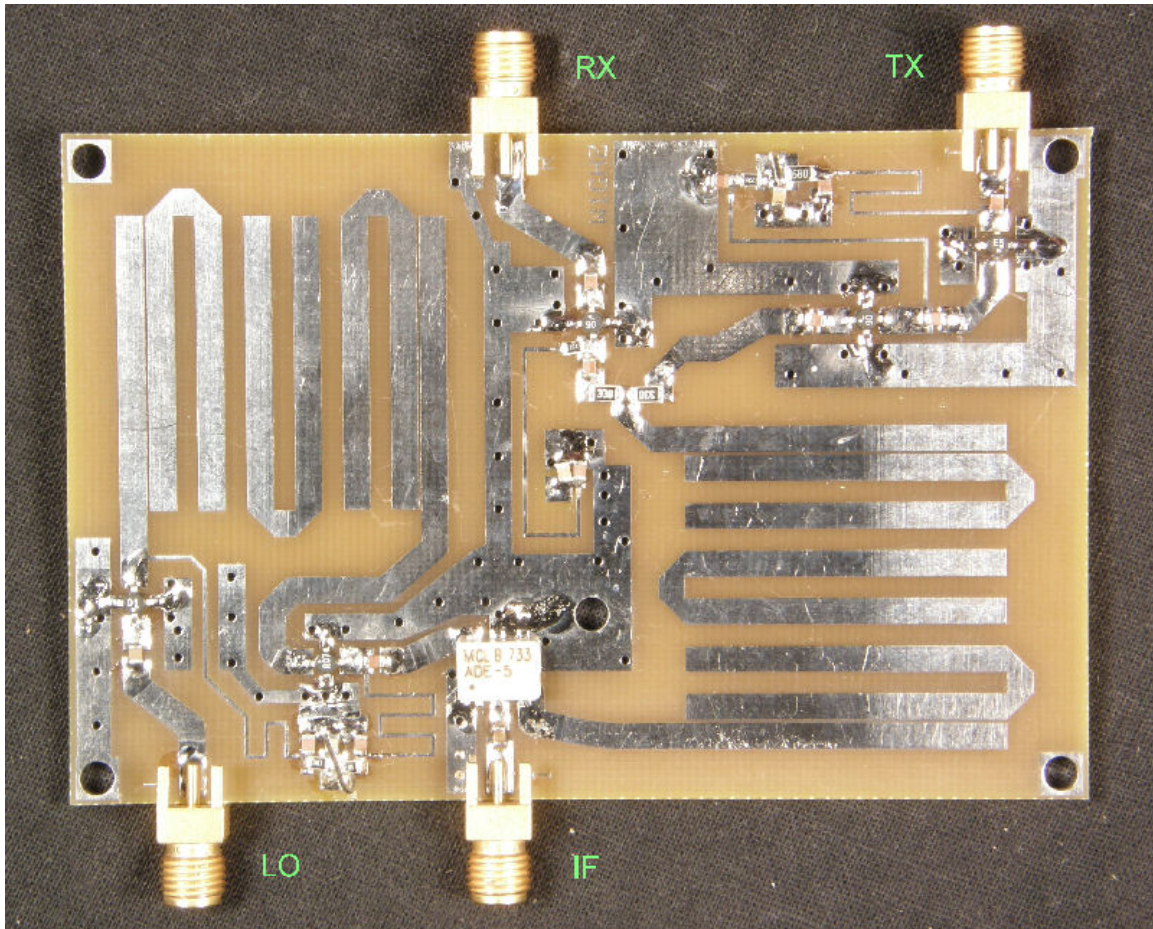

Figure 19 Transverter board for 1296 MHz

I chose another cheap mixer from Minicircuits, but not the same one used for 2304 and 3456 – models that cover all three bands are more expensive. Although the package looks the same, it uses a different pinout. Figure 20 shows the mixer and 1296 MHz printed hairpin filter.

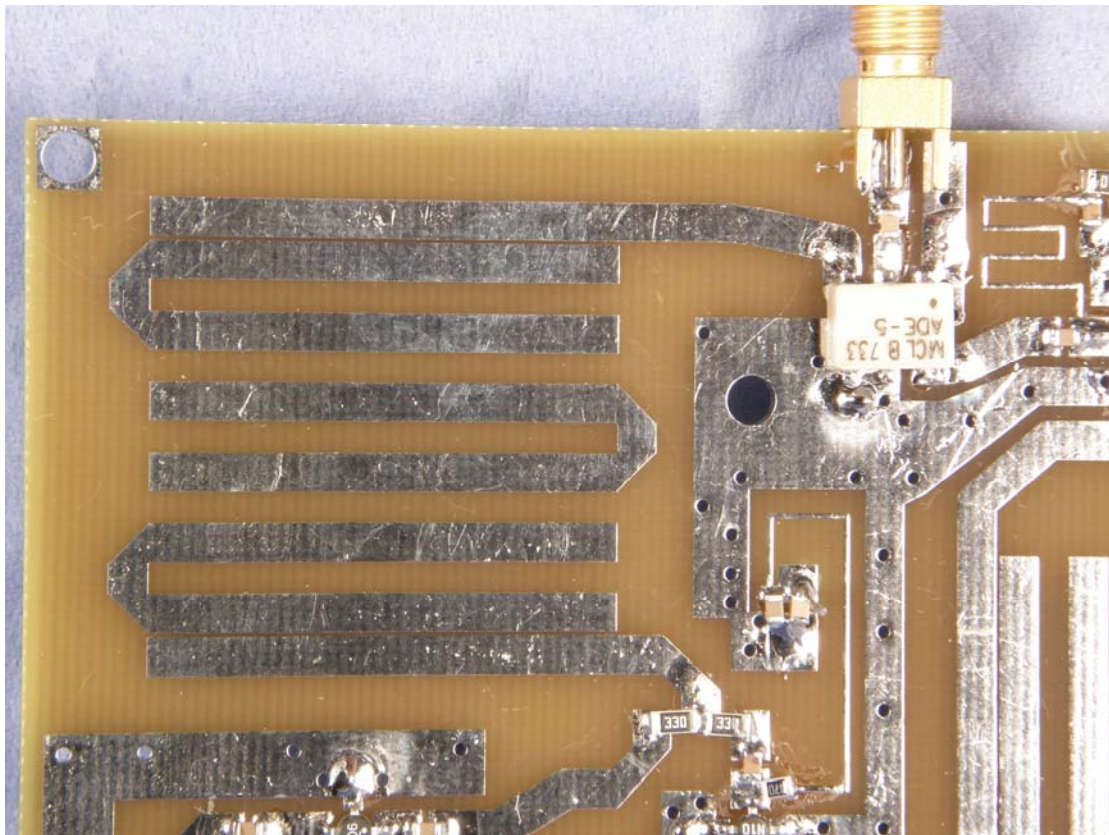

Figure 20 Mixer and 1296 MHz Hairpin Filter

All the other parts should be readily available and reasonably priced. The resistors and capacitors are commodity parts, not expensive microwave parts. The MMICs are available from Down East Microwave¹, and boards will be available if there is enough interest – or does everyone already have a 1296 transverter? There is probably enough activity on 1296 to justify a high-performance transverter rather than a simple one. But a simple one might be useful as a first IF for 24 GHz or higher bands.

The prototype used a MAR-6 MMIC for the receive amplifier, which does not provide enough gain to overcome the loss of the mixer, filter, and splitter, roughly 18 dB total loss. I replaced it with an INA-10386 MMIC for higher gain and better noise figure, at the expense of a little higher operating current.

Because of the limited filtering, the LO and image frequencies are only about 30 dB down. This is probably OK for rover operation, but not for long term or high power operation – the LO frequency, 1440 MHz is near enough to radio astronomy frequencies to attract some attention. For serious work, more filtering is needed, with real metal filters^{2,3}.

The final limitation is that the LO injection is high side, so that 1296.100 MHz comes out at 143.9 MHz, and tunes backwards, reversing USB and LSB. This can be annoying, but just remember that the cost of the whole transverter is about the same as the cost of a custom crystal.

Part 5: Coax Relay

For T-R switching, most microwave transverters use an SMA coax relay like the one in Figure 21. Good ones can be more expensive than one of these transverters, while surplus ones can be problematic – many are worn out and have intermittent contacts. Most of them require 28 volts to operate, and require more power than these transverters use.



One possible alternative is some of the PC-mount relays intended for “wireless” applications. The Omron G6Y relay in Figure 22 is rated for up to 10 watts at frequencies to 2.5 GHz, and operates from 12 volts. They are readily available for a few dollars, and Down East microwave uses them in some products. I tested one on the board shown – it looks good to about 3.5 GHz, with about 1 dB of loss. Part of the loss is probably due to the PC board.

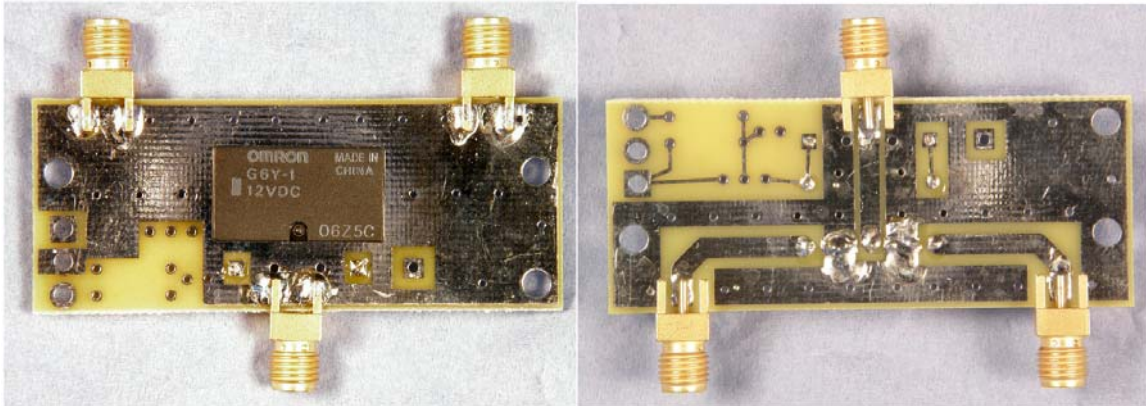

Figure 22 Inexpensive RF Relay – Omron G6Y-1

A similar relay, the Omron G6Z, shown in Figure 23, uses surface mount construction and gets slightly better performance, operating up to around 6 GHz with perhaps 3 dB of loss – hard to say how much is due to the PC board.

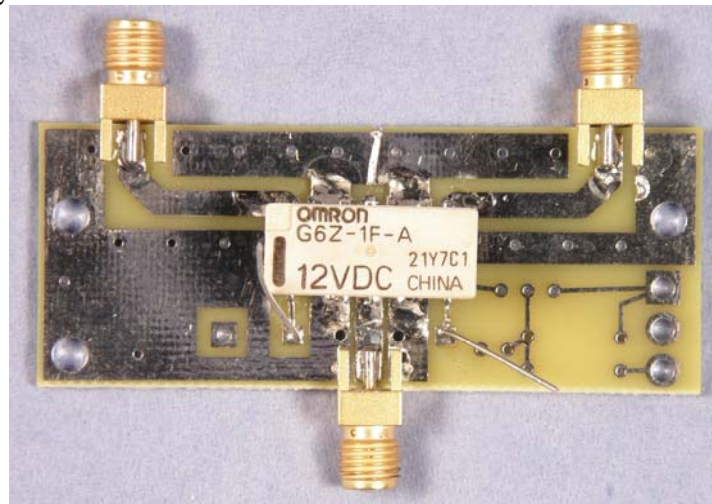

Figure 23 Surface Mount RF Relay – Omrom G6Z-1F-A

The small PC board for the relay is designed to line up with the TX and RX ports on all the transverters, to connect directly and eliminate several SMA connectors. Figure 24 shows a 1296 transverter with relay attached, connecting each transmission lines with a couple of wires in parallel. On the back side, the two ground planes are bridged together with Solder-wick braid, shown in Figure 25.

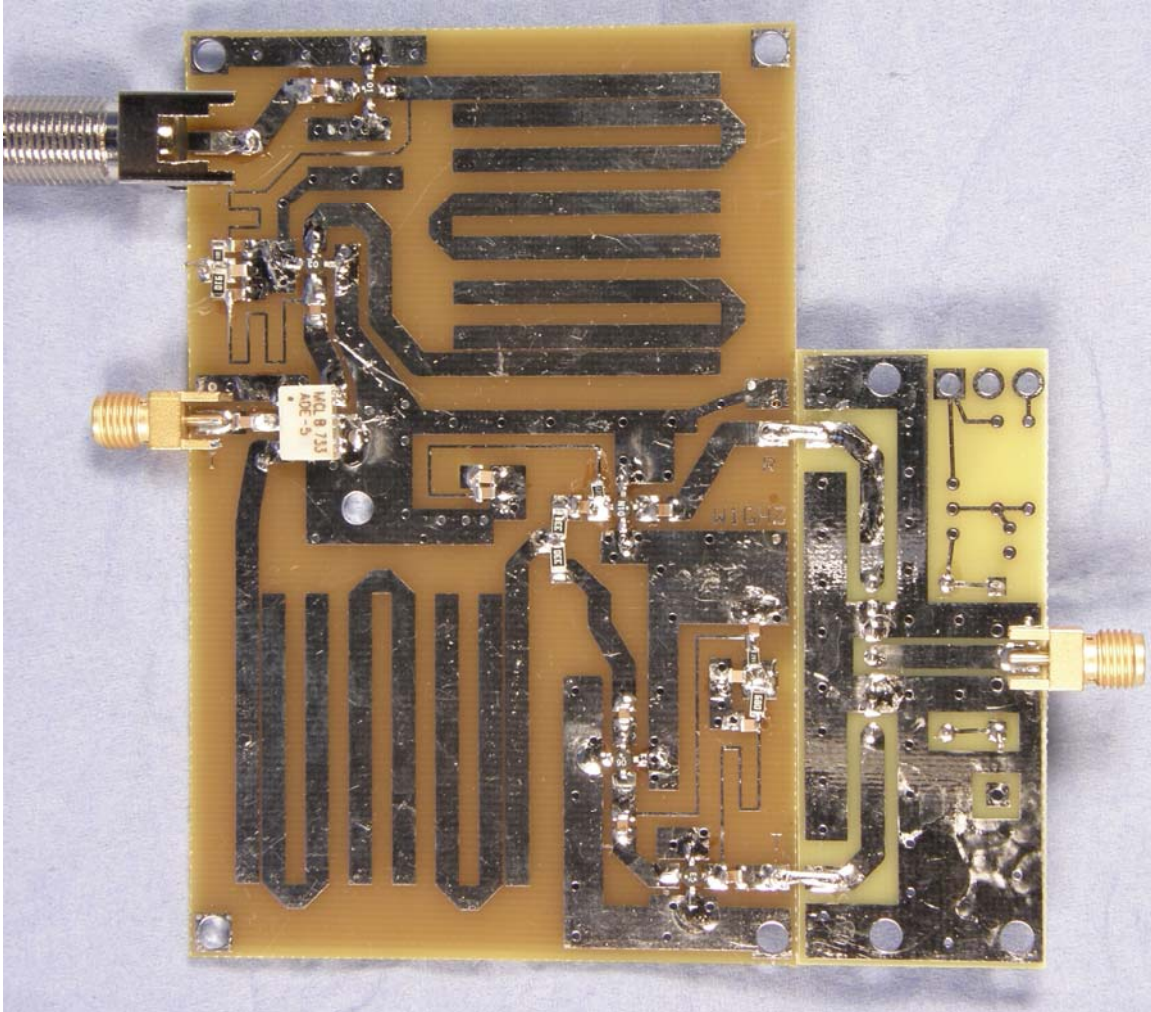

Figure 25 1296 Transverter with attached RF Relay

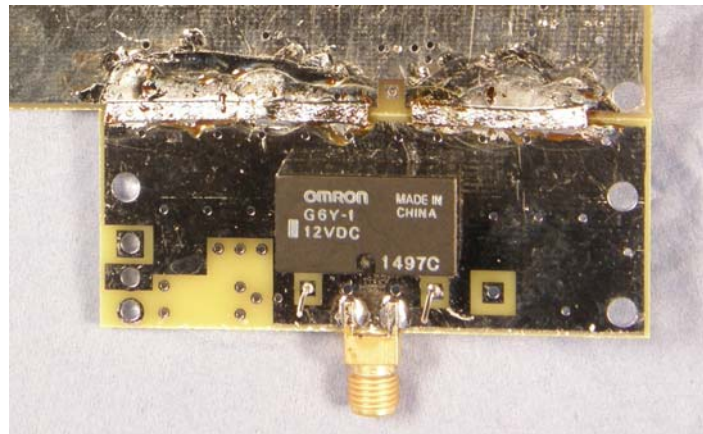

Figure 25 Ground plane side

Part 6: System

So far, we have described a basic transverter, not a complete system. For an operational station, we need something to interface with the IF transceiver. The **TC** (Transverter Control IF switch) kit from Down East Microwave⁸ will do the switchover, reducing power on transmit, and can also generate 24 volts for surplus coax relays. At these low power levels, we could skip the relay and use two separate antennas, perhaps modest horns.

Both transverter and LO boards are biased to run from an 8-volt supply. One easy way to get this is to change the 3-terminal regulator on the **TC** board to an 8-volt regulator like a 7808. The receive amplifier for 2304 or 3456 MHz, A1 on the transverter board, requires a lower voltage – a small adjustable 3-terminal regulator, like an LM317L, will do the job. Just remember bypass capacitors on both sides of the regulators or you may make an oscillator.

The complete unit should be packaged in some sort of metal box. The transverter board and LO board are best mounted to a metal surface on short standoffs, with the MMIC side of the boards facing the metal surface to reduce stray radiation.

If multiple transverters are to be sourced from one LO board, a power splitter is needed, followed by some gain to make up the splitter loss. A sketch for a power splitter is shown in Figure 26. Resistor R should be 51 ohms for a two-way splitter, 100 ohms for a three-way, or 150 ohms for a four-way splitter. Gain to get back to the input level is about 6 dB for a two-way splitter, plus another 3 dB for each additional output. A fancy PC board isn't really needed – a quick X-Acto knife special, or a perf board or just dead-bug construction will do the job. A couple of extra dB of gain from the MMICs will make up for any imperfections.

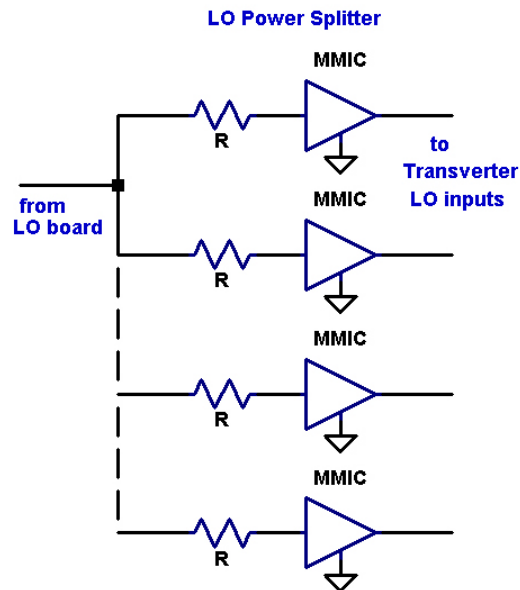

Figure 26. LO power splitter

Another choice for the power splitter would be the inexpensive ones made for satellite TV distribution. They are nominally 75 ohms and have Type-F connectors. A selection is shown in Figure 27. They work well in a 50 ohm system from about 300 MHz to >1300 MHz, with each output about 6 dB down. The exception is the unit in the lower right, which seems to be a diplexer, separating different frequency bands. So make sure to use one marked “SPLITTER.”

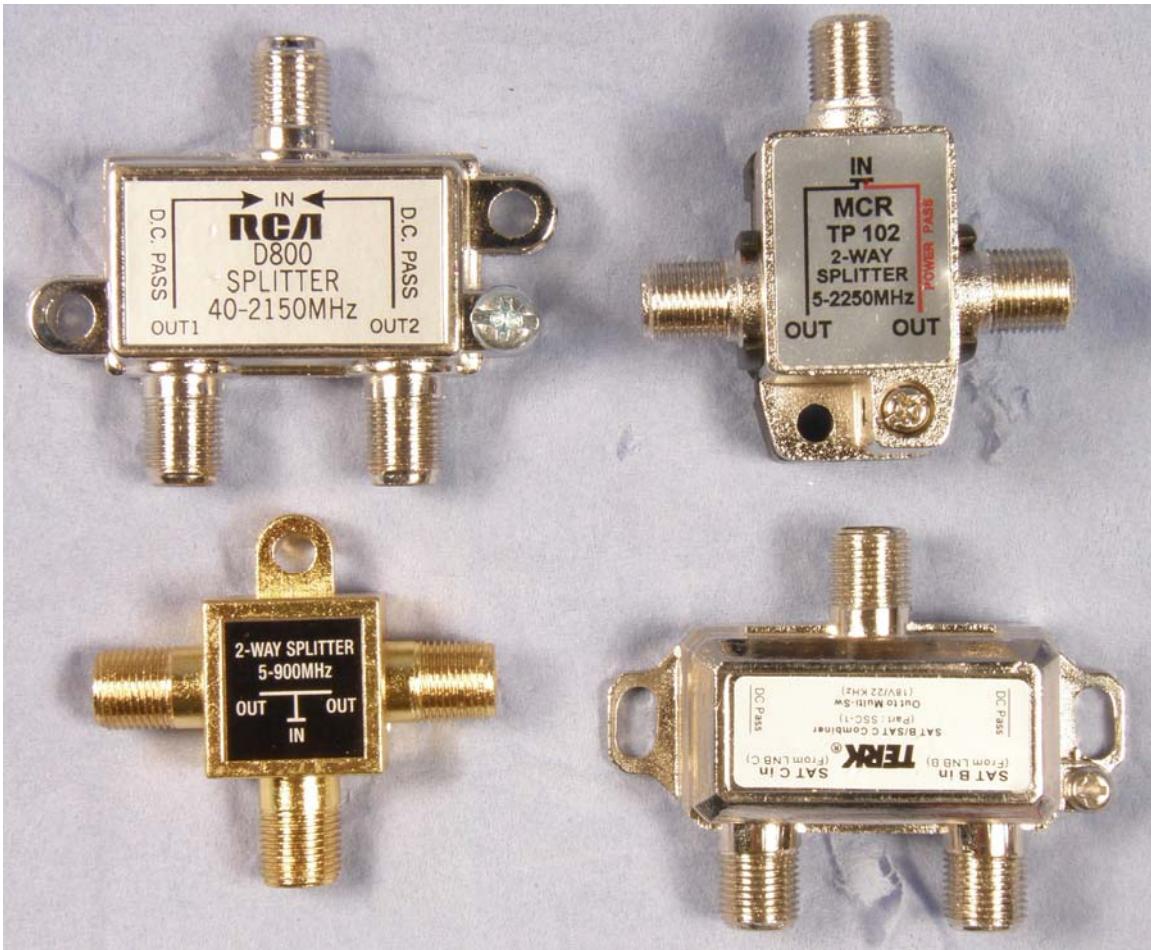

Figure 27 CATV Splitters make good LO power splitters.

There is always the temptation to go for higher performance. Surplus power amplifiers are available for both bands, and C-band TVRO equipment can be converted into an inexpensive low-noise preamp. I'd strongly suggest adding real filters, metal ones⁹, before driving a high power amplifier or with a preamp.

Other Bands

I haven't yet made transverters for the other bands that fit into this LO scheme, but the foundation is there, and you needn't wait for me. For 10368 MHz, we can generate a 10800 MHz LO for a 432 MHz IF by tripling the 3600 MHz LO we've already generated. One way would be to steal a small amount from the LO test point on the 3456 transverter – I think enough is available from stray coupling – to amplify and then multiply. My 10 GHz single-board transverter¹⁰ is an example for the rest.

5760 MHz is more difficult, since it is the eighth harmonic of 720 MHz. Three possibilities occur to me:

1. Direct conversion – this is fixed frequency and probably would not work very well.
2. Since most stations have IF transceivers that can tune a 4 MHz range, use an 80 meter IF and operate 3.5 MHz from the calling frequency, arranging it on the lower bands.
3. 2304 MHz plus 3456 MHz equals 5760 MHz. Bring the other two transverters together in a mixer, driving one with a fixed 144 MHz signal to act as an LO for the other, tunable, signal.

A final use might be for radio astronomy. The 1440 MHz LO could be used to convert the 1420 MHz hydrogen line down to 20 MHz.

A bit of history

The description above sounds carefully planned and engineered, but it really wasn't. I started with two ideas: the 720 MHz scheme for multiple bands, and the two-band pipe cap transverter. Even though I hadn't figured out how to get to 720 MHz, I built a transverter. It didn't work! The LO stages had very low gain and tuning was impossibly sharp. At first, I thought something was wrong with the MMICs. I set it aside for a while.

Over time, I kept thinking about it, and finally figured out workable filters for the 720 MHz board. Then I went back and analyzed the pipe-cap filters¹¹, and realized that the probes I had used were much too short, making the filters very sharp and lossy. Once the probes were corrected, things started to work. Then I found that the mixer footprint was backwards on the board, so I had to patch a mixer on. But it still worked, so I corrected the board and made some more, to show the transverter is reproducible.

The lesson here is to stick with an idea long enough to see if it's a good one. It may not go where you planned, but you won't know without trying.

Antennas

Simple horn antennas can provide good results for a rover station, providing good gain in a robust, easy to point, package. With a little effort, we could come up with a dual-band horn for 2304 and 3456 MHz.

A small dish antenna can provide a bit more gain at the expense of a narrower beam, making aiming more critical. Multiband feeds are not optimum, but are simple and good for rover use. I'd recommend WA5VJB's log periodic¹² as a multiband dish feed¹³ or just as a small antenna with modest gain. A log periodic also works fine as a simple rover antenna with about 6 dB gain, plenty for shorter contacts.

For more antenna details, see the *W1GHZ Microwave Antenna Book – Online*¹⁴.

Summary

These microwave transverters should be relatively simple to build, and fun for those who enjoy homebrewing. I believe there are enough hams who still homebrew to justify having some boards made and making them available. These transverters can be used in an affordable basic system or as building blocks for higher performance.

Board layouts, parts lists, and closeup photos are available on my website, www.w1ghz.org.

References

1. Wade, Paul, W1GHZ, "A 222 MHz transverter for the Yaesu FT-817," *QST*, January 2003, pp. 31-38.
2. www.ansoft.com
3. www.avx.com
4. www.expresspcb.com
5. Paul Wade, N1BWT, "A Single-board Transverter for 5760 MHz and Phase 3D," *QEX*, November 1997, pp 2-14. also www.w1ghz.org/10g/QEX_articles.htm
6. www.minicircuits.com
7. Judson Snyder, K2CBA, "The 10 GHz Easyverter," *Proceedings of the 25th Eastern VHF/UHF Conference*, ARRL, 1999, pp. 371-376.
8. www.downeastmicrowave.com
9. Paul Wade, W1GHZ, "Waveguide Interdigital Filters," *QEX*, January 1999, pp. 3-8.
10. Paul Wade, W1GHZ, "A Single-Board Transverter for 10 GHz," *Proceedings of the 25th Eastern VHF/UHF Conference*, ARRL, 1999, pp. 381-396. also in Andy Barter, G8ATD, ed., *International Microwave Handbook*, RSGB & ARRL, 2002, pp. 365-372.
11. Paul Wade, W1GHZ, "Pipe-cap Filters Revisited," www.w1ghz.org/new/Pipe-cap_Filters_Revisited.pdf
12. Kent Britain, WA5VJB, "Designing PCB Log Periodic Antennas," *Proceedings of Microwave Update 2000*, ARRL, 2000, pp. 203-208. www.wa5vjb.com
13. Paul Wade, W1GHZ, "The WA5VJB LPA Antenna as a Multi-band Dish Feed," *Proceedings of the 38th Conference of the Central States VHF Society*, ARRL, 2004, 158-166.
14. Paul Wade, W1GHZ, *W1GHZ Microwave Antenna Book – Online*, www.w1ghz.org